

ARTICULO: 2528A

Válvula de esfera paso total Bridada, ANSI Clase 150, Acero Inox Stainless Steel full port ball valve, ANSI Class 150, Flanged ends

Características

1. Válvula de esfera paso total, 2 piezas.
2. Extremos Bridados según ASME B 16.5. ANSI Clase 150.
3. Construcción en Acero Inoxidable CF8M.
4. Normas de diseño ASME B 16.34.
5. Longitud entre caras según ASME B 16.10.
6. Asientos PTFE + 15 % F.V.
7. Junta de cuerpo :
PTFE + Grafito (de ½" a 1 ¼")
AISI 304 + Grafito (de 1 ½" a 8")
8. Certificación Fire Safe según EN 10497.
9. Vástago inexpulsable.
10. Montaje actuador directo según ISO 5211.
11. Sistema de bloqueo incorporado.
12. Dispositivo Antiestático.
13. Inspección y ensayos según API 598.
14. Presión de trabajo máxima 19 bar (275 psi).
15. Temperatura de trabajo -30 °C + 180 °C.

Features

1. Full port ball valve, 2 pieces.
2. Flanged ends according to ASME B 16.5. ANSI Class 150.
3. Made of Stainless Steel CF8M.
4. Design according to ASME B 16.34.
5. Face to Face according to ASME B 16.10.
6. Ball seats PTFE + 15 % G.F.
7. Body gasket:
PTFE + Graphite (from ½" to 1 ¼")
AISI 304 + Graphite (from 1 ½" to 8")
8. Fire Safe certification according to EN 10497.
9. Blow-out proof stem.
10. Direct mounting actuator acc. to ISO 5211.
11. Block System.
12. Antistatic device.
13. Inspection & Testing: API 598
14. Max. working pressure 19 bar (275 psi).
15. Working Temperature -30 °C + 180 °C.

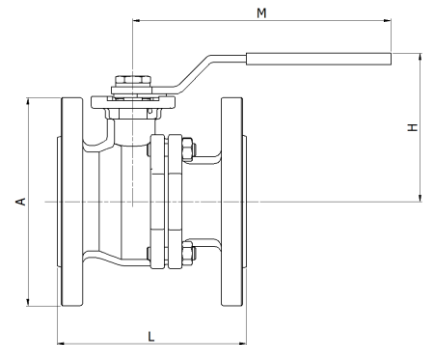
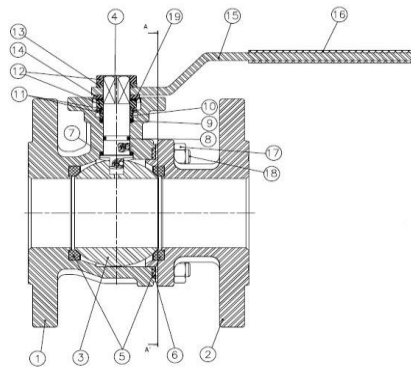

Nº	Denominación / Name	Material	Acabado Superficial / Surface Treatment	Ref.
1	Cuerpo / Body	Acero Inox. CF8M / SS CF8M (AISI 316)	Granallado / Shot blasting	-----
2	Tapa / Cap	Acero Inox. CF8M / SS CF8M (AISI 316)	Granallado / Shot blasting	-----
3*	Bola / Ball	Acero Inox. CF8M / SS CF8M (AISI 316)	-----	2907
4*	Eje / Stem	Acero Inox AISI 316 / SS 316	-----	2908
5*	Asiento / Ball seat	PTFE + 15% FV / GF	-----	2909

Nº	Denominación / Name	Material	Acabado Superficial / Surface Treatment	Ref.
6*	Junta / Gasket	PTFE + Grafito o AISI 304 + Grafito PTFE + Graphite or SS304 + Graphite	-----	2909
7*	Arandela / Trust Washer	PTFE + Grafito / PTFE + Graphite	-----	2909
8*	Tórica / O'ring	FKM (Viton)	-----	2909
9*	A. Prensa / Stem packing	PTFE	-----	2909
10	Anillo Prensa / Stem Ring	Acero Inox AISI 304 / SS 304	-----	-----
11	Arandela / Spring Washer	Acero Inox AISI 301 / SS 301	-----	-----
12	Tuerca / Nut	Acero Inox AISI 304 / SS 304	-----	-----
13	Arandela / Washer	Acero Inox AISI 304 / SS 304	-----	-----
14	Tope / Stopper	Acero Inox AISI 304 / SS 304	-----	-----
15	Maneta / Handle	Acero Inox AISI 304 / SS 304	-----	-----
16	Funda / Handle Sleeve	Vinilo / Vynil	-----	-----
17	Tuerca / Nut	Acero Inox AISI 304 / SS 304	-----	-----
18	Perno / Stud Bolt	A193 – B 8	-----	-----
19	Antigiro / Lock Washer	Acero Inox AISI 304 / SS 304	-----	-----

* Piezas que componen los Kit de Reparación / Repair Kit parts

Únicamente en medidas de 2 ½" a 6" / For 2 ½" – 6" Sizes Only

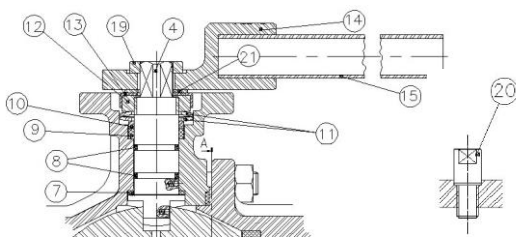

Nº	Denominación / Name	Material	Acabado Superficial / Surface Treatment
14	Cuerpo maneta / Body Handle	CF8	Decapado / Shot Blasting
19	Tuerca / Nut	AISI 304	-----
20	Tope / Stopper	AISI 304	-----
21	Antigiro / Lock Washer	AISI 304	-----

Únicamente en 8" / For 8" Size Only

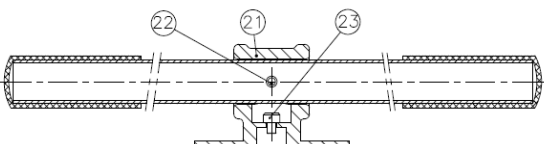

Nº	Denominación / Name	Material	Acabado Superficial / Surface Treatment
21	Cuerpo maneta / Body Handle	CF8	Decapado / Shot Blasting
22	Prisionero / Grub Screw	AISI 304	-----
23	Tornillo / Screw	AISI 304	-----

Dispositivo antiestático / *Anti-static device*

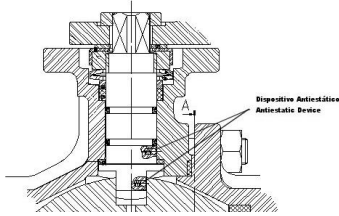

Este dispositivo nos garantiza la continuidad eléctrica entre esfera - eje - cuerpo, esto es de especial necesidad en fluidos inflamables. / *This device guarantees the electric continuity between Ball - Stem - Body, this is of special need with flammable fluids.*

Detalle de la zona de Eje / *Stem detail*

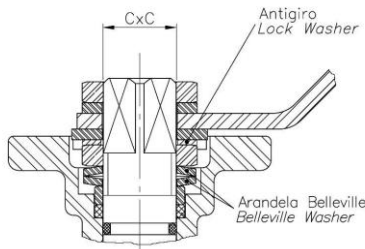

Antigiro / *Lock Washer*: Previene el desajuste de la tuerca del eje en elevados ciclos de maniobra / *Prevents unthreading of stem nut in high cycle automation applications.*

Arandela Belleville / *Belleville Washer*: Las arandelas belleville proporcionan una carga constante sobre el prensa asegurando un cierre firme en variaciones de condiciones de trabajo. / *Standard belleville washers provide constant "live load" on the stem seals, assuring a tight seal even varying service parameters.*

DIMENSIONES GENERALES / *GENERAL DIMENSIONS*

Ref.	Medida / Size	CLASE / CLASS	Dimensiones / Dimensions (mm)						ISO 5211	Peso / Weight (Kg)
			A	H	L	M	C x C			
2528A 04	1/2"	150	89	85	108	170	9 x 9	F04	1,500	
2528A 05	3/4"	150	98,6	85	117	170	9 x 9	F04/F05	2,150	
2528A 06	1"	150	108	95	127	170	11 x 11	F04/F05	2,870	
2528A 07	1 ¼"	150	117	106	140	200	14 x 14	F05/F07	3,950	
2528A 08	1 ½"	150	127	110	165	200	14 x 14	F05/F07	5,800	
2528A 09	2"	150	152,5	118	178	200	14 x 14	F05/F07	8,400	
2528A 10	2 ½"	150	177,8	170	190	380	17 x 17	F07/F10	13,500	
2528A 11	3"	150	190,5	170	203	380	17 x 17	F07/F10	17,800	
2528A 12	4"	150	228,6	170	229	380	17 x 17	F07/F10	30,500	
2528A 14	6"	150	279,4	225	394	620	27 x 27	F10/F12	56,000	
2528A 16	8"	150	342,9	340	457	800*	27 x 27	F12/F14	127,000	

* puede usarse también en forma de T / *can be used as T handle as well*

CURVA PRESIÓN TEMPERATURA / PRESSURE TEMPERATURE RATING

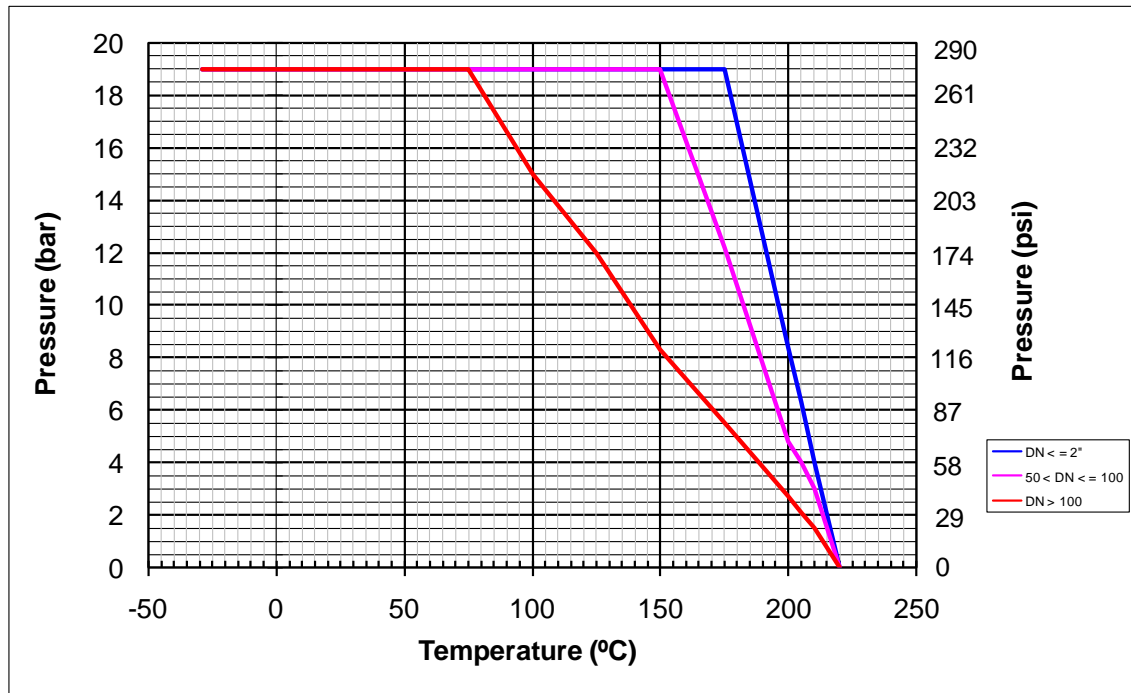

VALORES DE Kv / Kv VALUES

Kv (m³/h) = Es la cantidad de metros cúbicos por hora que pasará a través de la válvula generando una pérdida de carga de 1 bar.

Kv (m³/h) = Flow rate of water in cubic meter per hour that will generate a pressure drop of 1 bar across the valve.

1/2"	3/4"	1"	1 1/4"	1 1/2"	2"	2 1/2"	3"	4"	6"	8"
17	38	62	115	150	250	410	900	1450	3700	8000

