



Special Features

- Stainless steel case & stem
- Stem length available from 50 mm
- Bottom / back / every angle entry
- Silicon oil filled (optional)
- With or without thermowell
- External zero adjustment (optional)
- Standard followed EN 13190.

Application

- Chemicals
- Refinery
- Fertilizer
- Petrochemicals
- Pharmaceutical
- Power
- Cement
- Sugar
- Food
- Beverages
- Pulp
- Paper
- Allied process industries
Which are having corrosive
media / environment

Specifications

Standard Version : 50 mm = Range up to 150 °C Max.,
63 mm = Range up to 300 °C Max.,
80 mm, 100 mm, 125 mm & 150 mm = Range up to 500 °C Max.
(For compound ranges, refer range table)

Nominal range, measuring ranges & limits of error as per EN 13190

Accuracy	: Class 1 as per EN 13190
Ambient temperature	: -25° C to 65° C
Operating pressure	: 15 kg/cm ² (without thermowell)
Over range limit	: 110 % of full scale
Stem diameter	: 8 mm
Process connection	: ½" BSP (M) fixed

Case, Bezel & Clamp	: AISI 304 SS
Stem & Connection	: AISI 316 SS
Joints	: TIG argon arc welding
Sensing Element	: Bi - metal strip coiled

Protection	: IP 65
Dial	: Aluminum, black graduation on white background
Pointer	: Aluminum, black coloured, Slotted zero adjustable & Fixed for NS 50 mm & 63 mm
Zero adjustment	: Externally for mounting type 8 & 14, (Except NS 50 mm & 63 mm)
Window	: Sheet Glass
Gasket	: Neoprene

Standard version : Silicon oil filled

Accuracy	: Class 1 as per EN 13190
Ambient temperature	: Maximum 65°C
Window	: Plexi Glass
Dampening liquids	: Silicon Oil (Option QA & QZ)
Gasket & filling Plug*	: Viton
Other features	: Refer Specification of Standard Version

*Gasket & Filling plug of Viton.

Nominal Range (°C)	Measuring Range (°C)	Limits of Error (± °C)
-20 to +40	-10 to +30	1
-20 to +60	-10 to +50	1
-20 to +120	-10 to +110	2
-30 to +30	-20 to +20	1
-30 to +50	-20 to +40	1
-30 to +70	-20 to +60	1
-40 to +40	-30 to +30	1
-40 to +60	-30 to +50	1
-100 to +60	-80 to +40	2
0 to 60	10 to 50	1
0 to 80	10 to 70	1
0 to 100	10 to 90	1
0 to 120	10 to 110	2
0 to 160	20 to 140	2
0 to 200	20 to 180	2
0 to 250	30 to 220	2.5
0 to 300	30 to 270	5
0 to 400	50 to 350	5
0 to 500	50 to 450	5
0 to 600	100 to 500	10

Dimensions - Standard Version

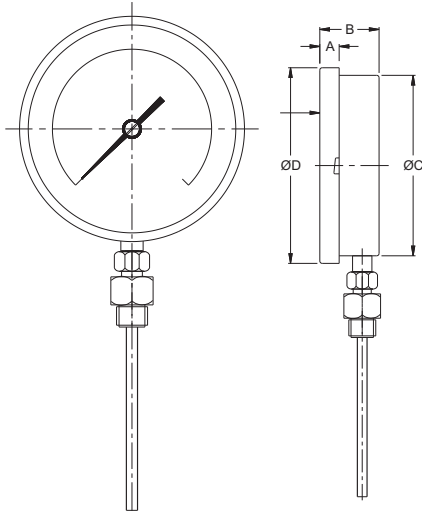

TYPE 2

NS	A	B	ØC	ØD	Approx. Wt.#
63	12.5	46	66.5	77.5	200.0
80	11	46	80	89.5	250.0
100	12.5	47	100	111	500.0
125	15	48	119	131	750.0
150	15	49	149	161	1000.0

(# Weight in grams with box for 300 mm stem length.)

Notes : • Drawings are not to scale. • All Dimensions are in mm. • NS = Nominal Size.

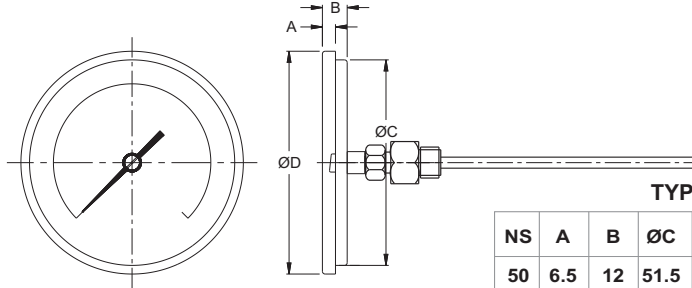

TYPE 4

NS	A	B	ØC	ØD	Approx. Wt.#
50	6.5	12	51.5	57.5	115.0
63	9.5	16	60	69.5	150.0
80	11	16	80	89.5	250.0
100	9.5	18	100	111	350.0
125	10	20	119	131.5	500.0
150	15	25.5	149	161	750.0

(# Weight in grams with box for 300 mm stem length.)

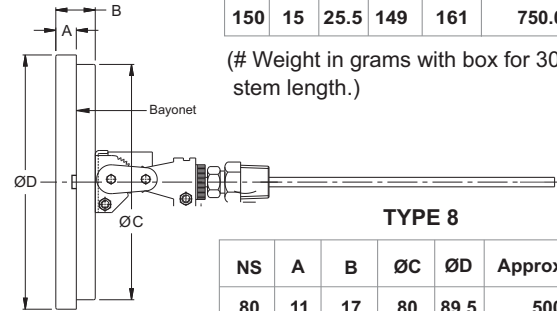
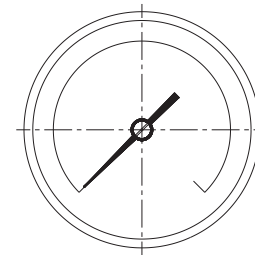

TYPE 8

NS	A	B	ØC	ØD	Approx. Wt.#
80	11	17	80	89.5	500.0
100	12.5	19	100	111	750.0
125	15	23	119	129	900.0
150	15	23	149	161	1000.0

Range Table

Range, stem OD & stem length selection table

The following table indicates the minimum and maximum stem lengths in mm, per stem diameter per range. The lower values indicated are the minimum immersion length (below thread) for all type of threads. During stem length selection, please select between the limits mentioned below.

(Range) °C	Ø 6 mm/ 6.34 mm.	Ø 8, 9.5 & 10 mm.	Ø 12 mm.
-20 /40	115 / 500	95 / 600	95 / 600
-20 /60	95 / 500	75 / 600	75 / 600
-20 /120	65 / 500	55 / 600	55 / 600
-30 /30	115 / 500	95 / 600	95 / 600
-30 /50	95 / 500	75 / 600	75 / 600
-30 /70	85 / 500	55 / 600	75 / 600
-40 /40	95 / 500	75 / 600	75 / 600
-40 /60	85 / 500	75 / 600	75 / 600
-80 /80	65 / 500	55 / 600	55 / 600
0 /60	115 / 500	95 / 600	95 / 600
0 /80	95 / 500	75 / 600	75 / 600
0 /100	65 / 500	50 / 600	75 / 600
0 /120	50 / 500	40 / 600	55 / 600
0 /160	45 / 500	35 / 600	55 / 600
0 /200	40 / 500	30 / 600	45 / 600
0 /250	45 / 500	45 / 600	45 / 600
0 /300	65 / 500	55 / 600	55 / 600
0 /400	55 / 500	45 / 600	45 / 600
0 /500	55 / 500	45 / 600	45 / 600

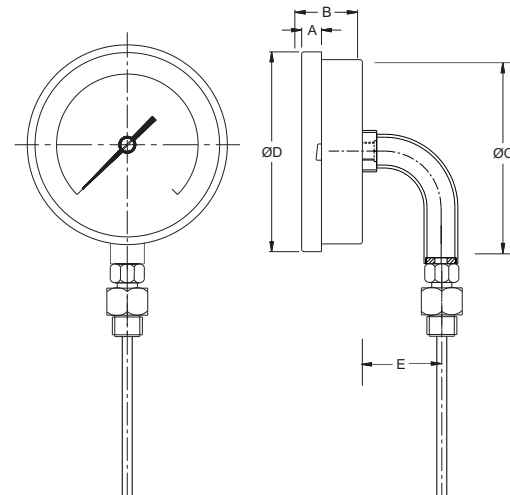

TYPE 14

NS	A	B	ØC	ØD	E	Approx. Wt.#
63	12.5	16	66.5	77.5	35	150.0
80	11	17	80	89.5	35	200.0
100	12.5	19	100	111	35	250.0
125	15	21	118.5	129	35	350.0
150	15	21	149	161	35	500.0

(# Weight in grams with box for 300 mm stem length.)

Dimensions - Standard Version

Note : We offer National / International Scales like °C, °F & Dual Scale in °C & °F & Scales as per the requirement can be provided on request. Following are the example tables for ranges in °C.

Standard Ranges

Positive range single scale in °C									
0/60	0/80	0/100	0/120	0/160	0/200	0/250	0/300	0/400	0/500
Compound range single scale in °C									
- 20 / 40	- 20 / 60	- 20 / 120	- 30 / 30	- 30 / 50	- 30 / 70	- 40 / 40	- 40 / 60	- 80 / 80	

ACCESSORIES (* Refer datasheet for Thermowells) Note : Other Scales are available on request.

* Thermowell

How To Order

Example

Basic Model

Code		C	D	E	F	G	H	
Nominal Size (mm)		50 mm	63 mm	80 mm	100 mm	125 mm	150 mm	CB X
Type of Mounting								
2	Direct bottom entry	X	✓	✓	✓	✓	✓	
4	Direct center back entry	✓	✓	✓*	✓*	✓*	✓*	X OR
8	Every angle back entry	X	X	✓*	✓*	✓*	✓*	XX
14	Bottom entry through elbow	X	✓	✓*	✓*	✓*	✓*	

* Available with external zero adjustment, Refer option RS.

Pressure Connection								
1BM	1/8" BSP(M) (Stem Dia. Max. 6.35 mm)	✓	✓	X	X	X	X	
1NM	1/8" NPT(M)* (Stem Dia. Max. 6.35 mm)	✓	✓	X	X	X	X	
2BM	1/4" BSP(M) (Stem Dia. Max. 6.35 mm)	✓	✓	X	X	X	X	
2NM	1/4" NPT(M)* (Stem Dia. Max. 6.35 mm)	✓	✓	X	X	X	X	
3BM	3/8" BSP(M) (Stem Dia. Max. 10 mm)	X	✓	✓	✓	✓	✓	XXX
4BM	1/2" BSP(M)(Standard) (Stem Dia. Max. 12 mm)	X	✓	✓	✓	✓	✓	
4NM	1/2" NPT(M)* (Stem Dia. Max. 12 mm)	X	✓	✓	✓	✓	✓	
4MM	M 20 x 1.5 (Stem Dia. Max. 12 mm)	X	✓	✓	✓	✓	✓	
4YN	1 1/2" TRICLOVER** (Stem Dia. Max. 12 mm)	X	✓	✓	✓	✓	✓	

* Not recommended for Revolving/ Swivel connections. ** Without clamp, gasket & bottom mating part.

Note : Connections like Metric/ PT/ PF/ Flaired/ UNF/ G/ R etc can be provided on request.

Process Connection Type (* Welded with stem / case & not suitable for taper threaded connections)

ZI	Adjustable	ZJ	Fixed (Standard)*	KJ	Revolving / Swivel	XX
-----------	------------	-----------	-------------------	-----------	--------------------	----

Stem Diameter

1U	6 mm	2M	6.35 mm	2C	8 mm (Standard)	2I	9.5 mm	2J	10 mm	2K	12 mm	XX
-----------	------	-----------	---------	-----------	-----------------	-----------	--------	-----------	-------	-----------	-------	----

Stem Length (Below thread Max. 600 mm) Please specify in mm (refer scale for minimum & maximum stem lengths)

Range

Refer range table

Optional extras (* Applicable for NS 100 mm & above)

PS	AISI 316 SS case & bezel (For NS 100 mm & above)*#	RS	External zero adjustment*	RH	Custom designed dial	XX
PW	Five point calibration certificate (for measuring range)		[except NS 50 mm & 63 mm (mounting type 2)]	SW	Dial tag marking*	
QA	Dampening liquid silicon oil (up to 200°C)**			GH	Material test certificates##	
QZ	Dampening liquid silicon oil (up to 300°C)**	RX	Shatterproof / safety glass*	SX	SS tag plate	
		RZ	Toughened glass*			

**Gasket & Filling plug of Viton. (# Consult factory for minimum order quantity & delivery.)

Material test certificates will be provided for wetted parts only with chemical composition testing. For others, please Consult factory.

Ordering Example: CB . X . X OR XX . XXX . XX . XX . 100 mm . 0/100°C . XX

For other optional items, please contact factory for delivery and minimum quantity of order.

Note : Specifications and dimensions given in this product catalogue represents the state of engineering at the time of printing.

Modifications may take place and materials specified may be replaced by others without prior notice.