



IBR



CE



UL Mark

### Special Features

- External zero adjustment (optional)
- Stainless steel case & measuring system
- Socket directly welded to case
- Dry and liquid filled version
- Standard followed EN 837-1 (for NS 100, 150 & 250 mm)
- CE marking (as per PED 97/23/EC) (for NS 100 mm & 150 mm)

### Application

- Food & beverage
- Pharmaceutical
- Cryogenics
- Pumps
- Diesel engines & Refrigerating plants
- Chemical & Petrochemical industries
- Conventional & nuclear power plants
- Environments & gaseous or liquid media that will not obstruct the pressure system.
- Hydro-cleaning machines
- Presses
- Engine compressors
- Turbines
- Suitable for corrosive

### Specifications

#### Standard Version : 100 mm, 125 mm, 150 mm, 200 mm & 250 mm

Accuracy	:	±1.0% of F. S.
Ambient temperature	:	- 25°C to + 65°C
Process temperature	:	Max 300°C
Operating pressure range	:	75% of Scale Value
Over pressure limit	:	≤ 100 bar : 125% of Max. Scale Value
	:	> 100 to ≤ 600 bar : 115% of Max. Scale Value
	:	> 600 to ≤ 1600 bar : 110% of Max. Scale Value

Case & Bezel	:	AISI 304 SS (Bayonet Type)
Bourdon	:	AISI 316L SS
Socket	:	AISI 316L SS (Directly Welded to Case)
Movement	:	AISI 304 SS
Joints	:	Tig Argon Arc Welding

Protection	:	IP 65
Dial	:	Aluminium, black graduation on white background
Pointer	:	Aluminium, black coloured Micrometer zero adjustable
Window	:	Sheet Glass
Blow off Disc	:	Neoprene
Gasket & Filling Plug	:	Neoprene

#### Dry But Fillable Version (Option FG)

Fillable Dampening Liquid	:	Glycerine 99.7% (Option - FG)
Ambient Temperature	:	Maximum 65°C
Process Temperature	:	Maximum 65°C
Window	:	Plexi Glass
Other Features	:	Refer Specification of Standard Version

#### Glycerine Filled Version (Option PY)

Accuracy	:	±1.0% of F.S.
Ambient Temperature	:	Maximum 65°C
Process Temperature	:	Maximum 65°C
Window	:	Plexi Glass
Dampening Liquids	:	Glycerine 99.7% (others available as option)
Other Features	:	Refer Specification of Standard Version

#### Temperature effect:

The variation of indication caused by effects of temperature is to be calculated by below formula; which is to be added in the specified accuracy while measurement :- Formula : ± 0.04 x (t2 - t1) % of F. S. where t1 = reference temperature (+20°C) and t2 = ambient temperature in °C.

**Dimensions - standard version**

**TYPE 1**

**TYPE 2**

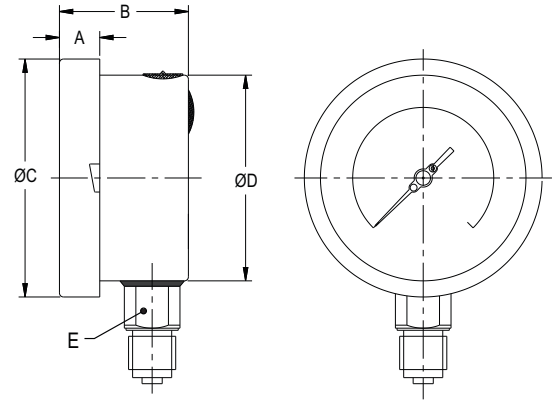
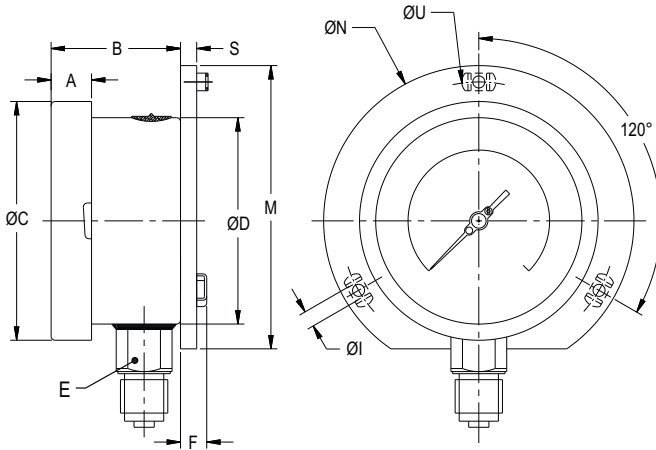

NS	A	B	ØC	ØD	E	M	S	F	ØI	ØN	ØU	Weight in gram (With Box)	Weight in gram (With Glycerin & Box)
100	12.5	45	111	100	22	128	6	14.5	6	134	118	720.0	1025.0
125	15	46	129	119	22	143	4	14.5	6	150	137	845.0	1165.0
150	15	46.5	161	149	22	174.5	6	14.5	6	186	168	1160.0	1895.0
200	18	49	216.5	201.5	22	229	1.5	14.5	7	245	230	2020.0	2780.0
250	18	52	263	250	22	286.5	1.5	14.5	7	290	276	2400.0	3220.0

NS	A	B	ØC	ØD	E	Weight in gram (With Box)	Weight in gram (With Glycerin & Box)
100	12.5	47	111	100	22	640.0	935.0
125	15	48	129	119	22	750.0	1070.0
150	15	49	161	149	22	1020.0	1755.0
200	18	49	210.5	201.5	22	1720.0	2480.0
250	18	52	263	250	22	2000.0	2820.0

**TYPE 3**

**TYPE 4**

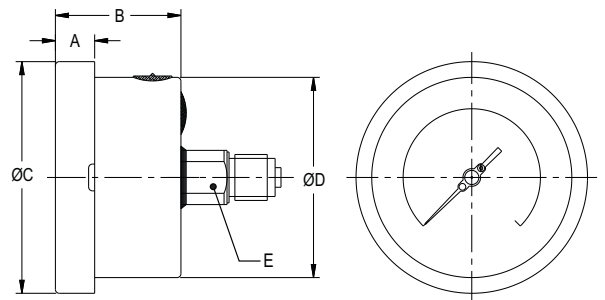
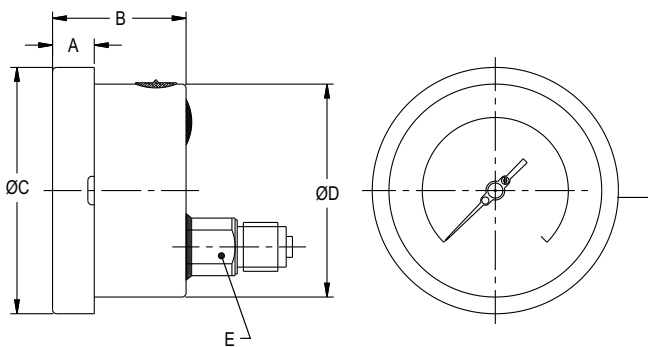

NS	A	B	ØC	ØD	E	Weight in gram (With Box)	Weight in gram (With Glycerin & Box)
100	12.5	47	111	100	22	640.0	935.0
125	15	48	129	119	22	750.0	1070.0
150	15	49	161	149	22	1000.0	1735.0
200	18	49	216.5	201.5	22	1500.0	2260.0
250	18	52	263	250	22	1800.0	2620.0

NS	A	B	ØC	ØD	E	Weight in gram (With Box)	Weight in gram (With Glycerin & Box)
100	12.5	47	111	100	22	640.0	935.0

**Dimensions - standard version**

**TYPE 5**

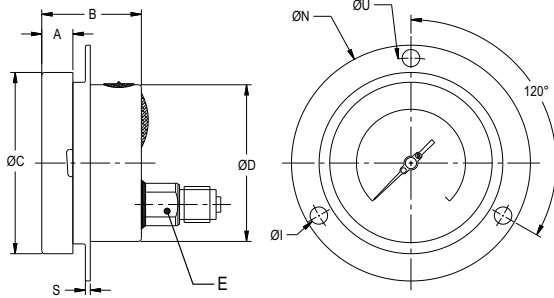

**TYPE 11**

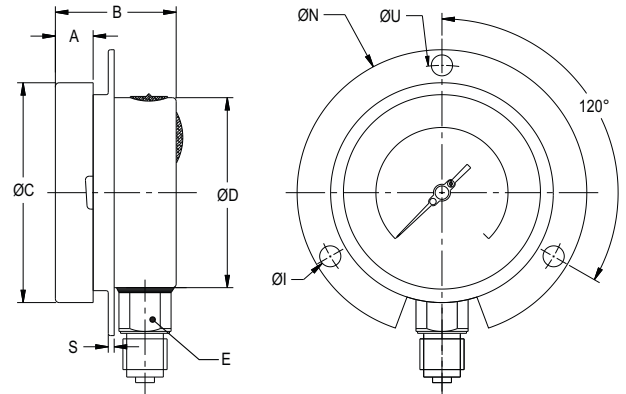

NS	A	B	ØC	ØD	E	S	ØI	ØN	ØU	Weight in gram (With Box)	Weight in gram (With Glycerin & Box)
100	12.5	45	111	100	22	1	6	134	118	695.0	990.0
125	15	46	129	119	22	1	6	150	137	850.0	1170.0
150	15	46.5	161	149	22	1	6	186	168	1100.0	1835.0
200	18	49	216.5	201.5	22	1.5	7	245	230	2000.0	2760.0
250	18	52	263	250	22	1.5	7	290	276	2250.0	3070.0

NS	A	B	ØC	ØD	E	S	ØI	ØN	ØU	Weight in gram (With Box)	Weight in gram (With Glycerin & Box)
100	12.5	47	111	100	22	1	6	134	118	730.0	1025.0
125	15	48	129	119	22	4	6	150	137	815.0	1135.0
150	15	49	161	149	22	5	6	186	168	1100.0	1835.0

**TYPE 9**

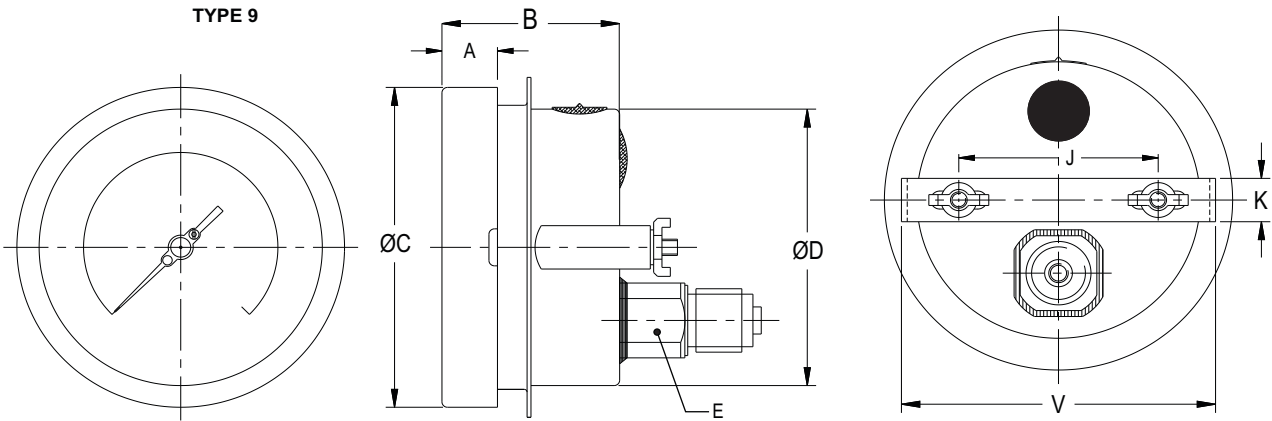

NS	A	B	ØC	ØD	E	J	K	V	Weight in gram (With Box)	Weight in gram (With Glycerin & Box)
100	12.5	47	111	100	22	72	16	108	740.0	1035.0
125	15	48	129	119	22	75	16	125	890.0	1210.0
150	15	49	161	149	22	106.5	16	166	1100.0	1835.0
200	18	49	210.5	201.5	22	165	16	208	1920.0	2680.0
250	18	52	263	250	22	180	30	270	2300.0	3120.0

Notes : • Drawings are not to scale. • All Dimensions are in mm . • NS = Nominal size  
• Weights mentioned are approximate and for standard product. Weight can be different after selection of options.

### Range Table

Note : We offer National / International Scales like kPa, MPa, bar, psi, kg/cm<sup>2</sup> & Dual Scale like kPa with psi, kPa with bar, bar with psi or Equivalent scales as per the requirement can be provided on request. Following are the example tables for kg/cm<sup>2</sup> & psi scales.

#### Pressure

##### Single Scale (kg/cm<sup>2</sup> or bar)

0/0.6	0/4	0/25	0/160	0/1000
0/1	0/6	0/40	0/250	0/1600
0/1.6	0/10	0/60	0/400	
0/2.5	0/16	0/100	0/600	

##### Dual Scale (psi with kg/cm<sup>2</sup>)

psi	kg/cm <sup>2</sup>	psi	kg/cm <sup>2</sup>	psi	kg/cm <sup>2</sup>
0/15	0/1	0/400	0/28	0/4000	0/280
0/30	0/2	0/500	0/35	0/5000	0/350
0/60	0/4	0/600	0/40	0/6000	0/420
0/100	0/7	0/1000	0/70	0/10000	0/700
0/150	0/10	0/1500	0/100	0/15000	0/1000
0/220	0/16	0/2200	0/160	0/22000	0/1600
0/300	0/20	0/3000	0/200		

#### Vacuum & Compound

##### Dual Scale (inHg with psi & mmHg with kg/cm<sup>2</sup>)

inHg with psi	mmHg with kg/cm <sup>2</sup>	inHg with psi	mmHg with kg/cm <sup>2</sup>	inHg with psi	mmHg with kg/cm <sup>2</sup>
- 30/0	- 760/0	- 30/60	- 760/4	- 30/200	- 760/14
- 30/15	- 760/1	- 30/100	- 760/7	- 30/300	- 760/21
- 30/30	- 760/2	- 30/150	- 760/10	- 30/350	- 760/25

##### Single Scale (kg/cm<sup>2</sup>)

- 1/0	- 1/1.5	- 1/5	- 1/15
- 1/0.6	- 1/3	- 1/9	- 1/24

#### Receiver

Linear scale	Square root scale
(0 - 100% Internal Scale)	( 0 - 10 Sq - Root Internal Scale )
External Scale	External Scale
0.2 - 1 kg/cm <sup>2</sup> or 3 - 15 psi	0.2 - 1 kg/cm <sup>2</sup> or 3 - 15 psi
(0-100% linear scale)	(0.2 - 1 kg/cm <sup>2</sup> )

#### Freon (with temperature scale)

#### Ammonia (with temperature scale)

Note : For temperature scales, please provide refrigerant name.

Range (psi)		( kg/cm <sup>2</sup> )	( psi )
-30 inHg - 150	0-300	-1 to 12.5	-30 inHg - 150
-30 inHg - 300	0-500	-1 to 16	-30 inHg - 300
		-1 to 25	0 - 300

#### Accessories (refer datasheet for complete specifications)

<b>EB</b> Cooling tower	<b>ED</b> Over load protector (gauge saver)**	<b>EG</b> Snubber
<b>EC</b> Gauge cock	* Needle valve	<b>EH</b> Siphon

\* Refer catalogue for Valves & Manifolds.

\*\* For Pressure Ranges.

How To Order	Example
--------------	---------

**Basic Model**
**Code**

Nominal Size	F	G	H	I	J
	100 mm	125 mm	150 mm	200 mm	250 mm

**Type of Mounting**

<b>1</b>	Wall / surface / projection mounting with bottom entry	AL  X  X OR XX
<b>2</b>	Direct bottom entry	
<b>3</b>	Direct lower back entry	
<b>4</b>	Direct center back entry (for NS 100 mm only)	
<b>5</b>	Lower back entry with front flange	
<b>6</b>	2" pipe / yoke mounting with bottom entry*	
<b>9</b>	Lower back entry with mounting bracket	
<b>11</b>	Bottom entry with front flange (for NS 100 mm, 125 mm & 150 mm)	

\* MOC of bracket and 'U' clamp will be steel (painted). Ask factory for drawings, if required.

Gauge Connection		F	G	H	I	J
<b>2BM</b>	1/4" BSP(M)	✓	✓	✓	X	X
<b>2NM</b>	1/4" NPT(M)	✓	✓	✓	X	X
<b>2TM</b>	1/4" BSPT(M)	✓	✓	✓	X	X
<b>3BM</b>	3/8" BSP(M)	✓*	✓	✓	✓	✓
<b>3TM</b>	3/8" BSPT(M)	✓	✓	✓	✓	✓
<b>4BM</b>	1/2" BSP(M) Standard	✓	✓	✓	✓	✓
<b>4NM</b>	1/2" NPT(M) Standard	✓	✓	✓	✓	✓
<b>4TM</b>	1/2" BSPT(M)	✓	✓	✓	✓	✓
<b>4MM</b>	M 20x 1.5(M)	✓	✓	✓	✓	✓

\* Standard for NS 100 mm.

**Note :** Connections like Metric/ PT/ PF/ Flaired/ UNF/ G/ R etc. can be provided on request.

**Range**

Refer range table

**Optional Extras**

<b>OA</b> Accuracy ± 0.5% of F. S. (for dry version)	<b>GH</b> Material test certificates***	<b>SB</b> Internal vacuum stop
<b>TI</b> Monel bourdon & socket (Monel version)**	<b>KA</b> ON - OFF type vent plug	<b>ZB</b> Receiver range
<b>FL</b> Integral dampening screw (Monel)	<b>PV</b> IBR approval #	<b>ZC</b> Freon range (with temperature scale)
<b>FS</b> Fillable liquid silicon oil*	<b>RG</b> Anti parallax mirror band dial ##	<b>ZD</b> Ammonia range (with temperature scale)
<b>FG</b> Fillable liquid glycerine	<b>EZ</b> External zero adjustment	<b>PS</b> AISI 316 SS case & bezel
<b>PY</b> Dampening liquid glycerine filled	<b>SX</b> SS tag plate	<b>SD</b> AISI 316 SS movement
<b>QA</b> Dampening liquid silicon oil filled*	<b>SW</b> Dial tag marking	<b>CK</b> Epoxy painted case & bezel
<b>RR</b> Enclosure protection IP 66	<b>TB</b> Helium leak test	<b>ZM</b> Electro polished case & bezel
<b>RE</b> Enclosure protection IP 67	<b>TF</b> Conformity as per NACE Standard	<b>SQ</b> Case with rolling type bezel (for NS 100 mm)
<b>RW</b> Plexi glass	<b>PW</b> Five point calibration certificate	<b>ZL</b> Over range protection 150% of F. S.
<b>RX</b> Shatterproof/safety glass	<b>PU</b> Calibration certificate traceable to National/International standards	<b>JU</b> 2" pipe/yoke mounting bracket & 'U' clamp (AISI 304 SS)
<b>RZ</b> Toughened glass	<b>SG</b> Oxygen service (for dry version)	<b>FN</b> 2" pipe/yoke mounting bracket & 'U' clamp (AISI 316 SS)
<b>SF</b> Movement with dampening jelly	<b>RH</b> Custom designed dial	<b>GO</b> Short over pressure
<b>SI</b> Knife edge pointer	<b>QB</b> Integral dampening screw (AISI 316 SS)	
<b>SJ</b> Maximum reading pointer with plexi glass (except option OA & only for dry version)◆	<b>SA</b> Internal over pressure stop	
<b>CE</b> CE marking (as per PED 97/23/EC)◆		

\* Gasket & Filling plug of for Viton. \*\*Integral dampening screw will be in monel if ordered. Refer option FL.

\*\*\*Material test certificates will be provided for wetted parts only with chemical composition testing. For others, please consult factory.

# For NS 150 mm & above. Scale shall be marked in kg/cm<sup>2</sup> only. Consult factory for more details.

## For NS 150 mm & Above. ◆ For NS 100 mm to 150 mm.

**Ordering Example: AL . X . X OR XX . XXX . 0/10 kg/cm<sup>2</sup> . XX**

**For other optional items, please contact factory for delivery and minimum quantity of order.**

Note : Specifications and dimensions given in this product catalogue represents the state of engineering at the time of printing.

Modifications may take place and materials specified may be replaced by others without prior notice.