

Temperature sensor type CT GB1

now available with
BV marine certificate

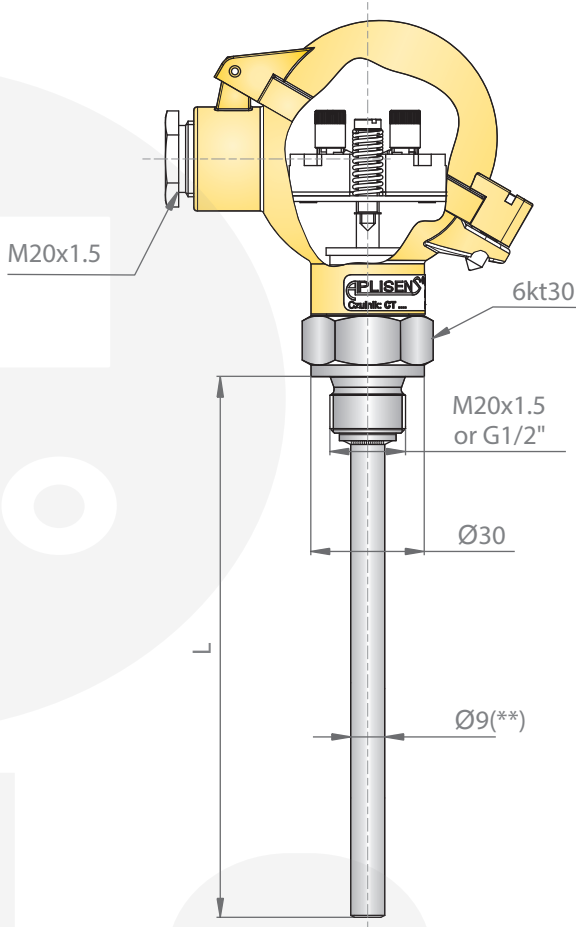

TECHNICAL DATA:

1. Measuring range:
Pt: -70...150°C / -196...150°C (*)
2. Admissible load:
see **Graph 2** (page X/ 17)
3. Material of wetted parts:
304ss or 316Lss (**)
4. Standard immersion length
L=100, 160, 250, 400 mm (**)
5. Process connection:
M20x1,5 or G1/2" (**)
6. Time constant:

Type of sensor	T _{0.5} [s]	T _{0.9} [s]
CT GB1	≤ 33	≤ 95

7. Diameter of the measuring insert:
Ø 6 mm
8. Minimal immersion depth:
90 mm
9. Admissible vibrations at mounting site:
5 ... 80 [Hz] (up to 5 [g])

- Ex I M1 Ex ia I Ma
- Ex II 1/2 G Ex ia IIC T6..T1 Ga/Gb
II 1D Ex iaD 20 T75°C Da

Ordering procedure with example of ordering code:

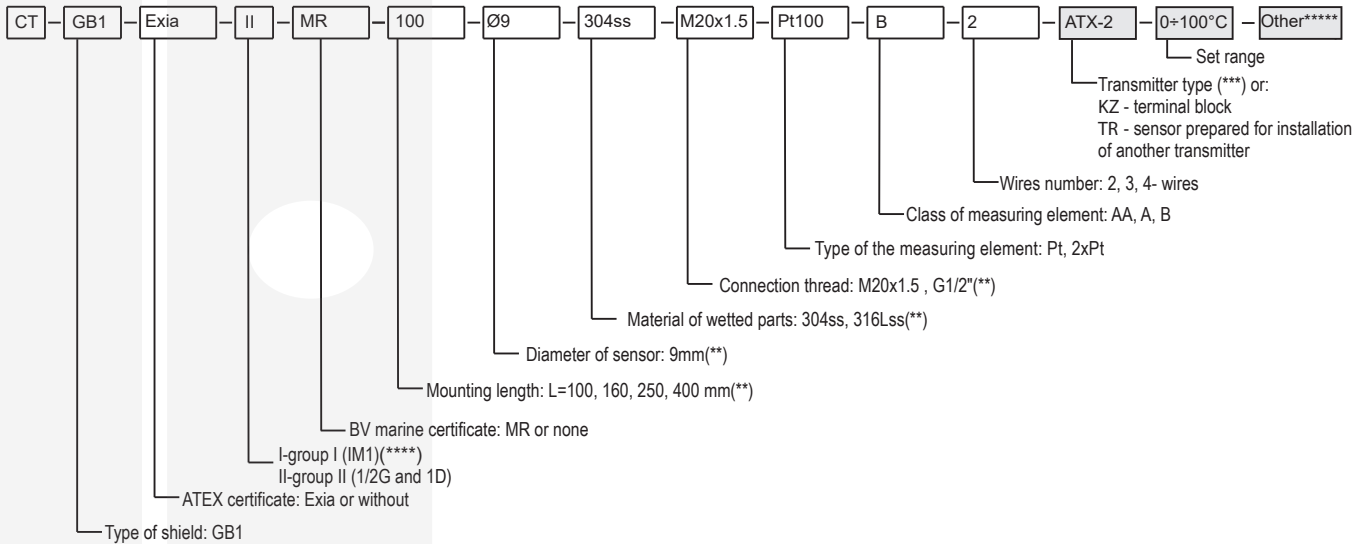

ADDITIONAL INFORMATION:

- 1.(*) Low temperature version: -196...150°C.
- 2.(**) Non-standard version of temperature sensors on request.
- 3.(***) Type of temp. transmitters: LI24-G, AT-2, GI-22-2, ATX-2, GIX-22-2 or other.
- 4.(****) Temperature sensor for group I is produced with stainless steel housing.
- 5.(*****) Additional required parameters acc. to transmitter data sheet.