

Pilot kick 2-port solenoid valve for steam

# SPK Series

- NC (open when energized)
- Working fluid: Steam
- Port size: Rc1/2 to Rc1



## JIS symbol

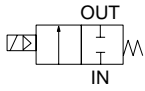

## Common specifications

Item	SPK11
Working fluid	Steam
Working pressure differential MPa	0 (≈0 psi, 0 bar) to 1.0 (≈150 psi, 10 bar)
Max. working pressure MPa	1 (≈150 psi, 10 bar)
Proof pressure (water pressure) MPa	2 (≈290 psi, 20 bar)
Fluid temperature °C	5 (41°F) to 180 (356°F)
Ambient temperature °C	-10 (14°F) to 60 (140°F)
Thermal class	Class 180 (H)
Atmosphere	Place free of corrosive gas and explosive gas
Valve structure	Pilot kick poppet, piston drive
Valve seat leakage (*2) cm <sup>3</sup> /min(ANR)	400 or less (air)
Mounting orientation	Limited to the range of vertical orientation with the coil on top to horizontal orientation (*3).

## Mounting orientation

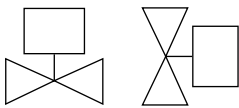

\*1 : No freezing.

\*2 : Value at pneumatic pressure of 0.05 to 1.0 MPa. When used at a pressure less than 0.05 MPa, the sealant may be unstable. Contact CKD in this case.

\*3 : Limited to vertical orientation when used at a pressure less than 0.05 MPa.

## Individual specifications

Item Model No.	Port size	Orifice size (mm)	Rated voltage	Apparent power (VA)				Power consump. (W) AC 50/60 Hz	Weight (kg)
				When holding		When starting			
				50 Hz	60 Hz	50 Hz	60 Hz		
SPK11-15A	Rc1/2	16	100 VAC 110 VAC 200 VAC 220 VAC	12	10	42	36	5.6/4.7	1.0
SPK11-20A	Rc3/4	23	1.3						
SPK11-25A	Rc1	28	1.7						

\*1 : The model numbers above show the basic port size (Rc). Refer to How to order for other combinations.

\*2 : The voltage fluctuation range must be within ±10% of the rated voltage. If the pressure difference is more than 0.7 MPa, it should be within -5% to +10%.

## How to order

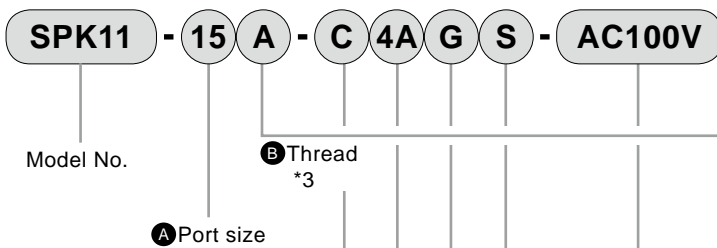

Code	Description
<b>A Port size</b>	
15	1/2
20	3/4
25	1
<b>B Thread</b>	
A	Rc
G	G (made-to-order product)
N	NPT (made-to-order product)
<b>C Body material</b>	
C	Bronze
K	Bronze/oil-prohibited
F	Stainless steel
N	Stainless steel/oil-prohibited
<b>D Coil housing</b>	
4A	Lead wire
4M	Terminal box
4N	Terminal box with lamp
<b>E Coil option</b>	
Blank	No option
G *1	Conduit CTC19
H *1	Conduit G1/2
<b>F Surge suppressor</b>	
Blank	Without surge suppressor
S *2	Surge suppressor attached
<b>G Rated voltage</b>	
AC100V	100 VAC 50/60 Hz, 110 VAC 60 Hz
AC200V	200 VAC 50/60 Hz, 220 VAC 60 Hz
AC110V	110 VAC 50/60 Hz, 121 VAC 60 Hz
AC220V	220 VAC 50/60 Hz, 242 VAC 60 Hz

## Precautions for model No. selection

\*1 : "G" and "H" are available only when the coil housing (D) is "4A".

\*2 : "S" is available only when the coil housing (D) is "4A".

\*3 : When ordering a stainless steel body with G bolts or NPT bolts, contact CKD.

## [Example of model No.]

### SPK11-15A-C4AGS-AC100V

- A Port size : 1/2
- B Thread : Rc
- C Body material : Bronze
- D Coil housing : Lead wire
- E Coil option : Conduit CTC19
- F Surge suppressor : Surge suppressor attached
- G Rated voltage : 100 VAC 50/60 Hz, 110 VAC 60 Hz

### Internal structure and parts list

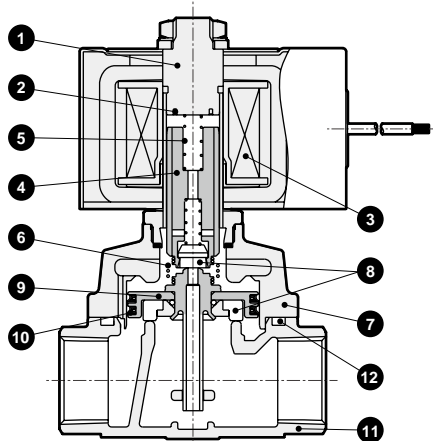

No.	Part name	Material
1	Core assembly	SUS 405 or equiv./SUS 316L/SUS 430
2	Shading coil	Cu (Ag for stainless steel body)
3	Coil	-
4	Plunger assembly	SUS 405 or equiv./SUS 304/PFA
5	Plunger spring	SUS304
6	Kick spring	SUS304
7	Body	CAC408(SCS13)
8	Seal	PTFE/PFA
9	Main valve assembly	SUS303/SUS304/PTFE
10	Seal ring set	SUS304/PTFE
11	Body	CAC408(SCS13)
12	Square ring	PTFE

### Dimensions

#### ● Lead wire

SPK 11-15A/20A/25A-\*4A

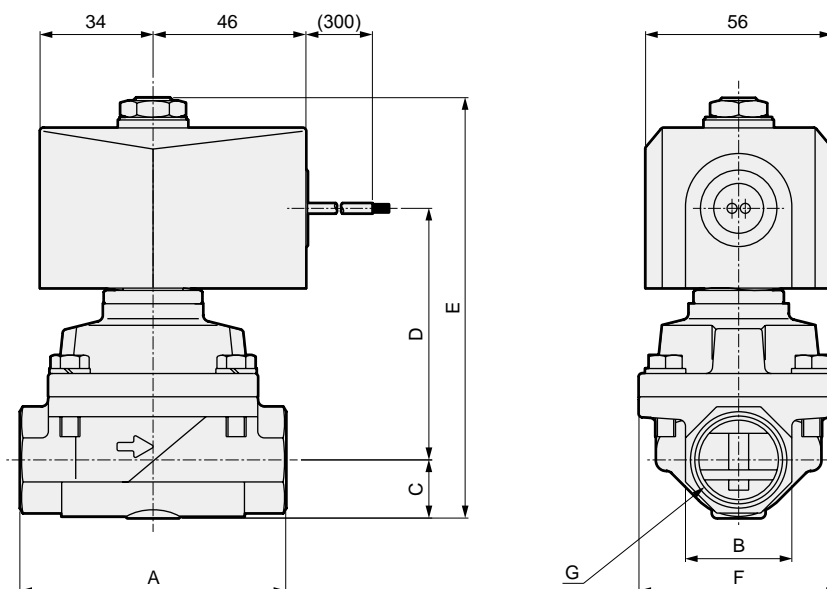

Model No.	A	B	C	D	E	F	G
SPK11-15A-*4A	71	27(29)	14.5	72	119.5	50	Rc1/2
SPK11-20A-*4A	80	32(35)	17.5	76	126.5	60	Rc3/4
SPK11-25A-*4A	90	41(45)	21.5(22.5)	82	136.5(137.5)	71	Rc1

\*1 : Dimensions shown in ( ) are for stainless steel body.

\*2 : The dimensions are the same for port sizes of G and NPT threads.

### Optional dimensions

#### ● Terminal box

SPK11-15A to 25A-\*4

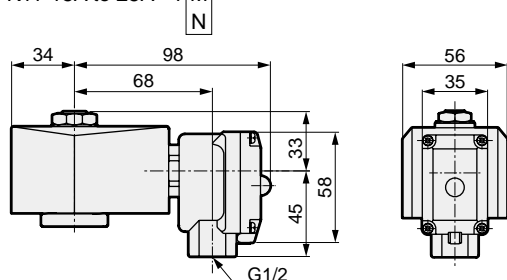

#### ● Conduit

SPK11-15A to 25A-\*4A

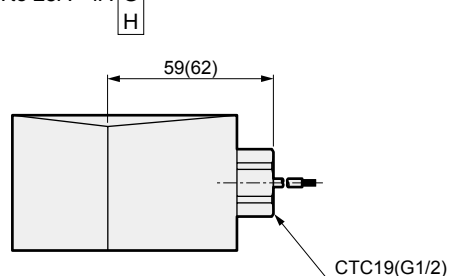

Dimensions shown in ( ) are for G1/2.

EXA  
FWD  
HNB/G  
USB/G  
FAB/G  
FGB/G  
FVB  
FWB/G  
FHB  
FLB  
AB  
AG  
AP/  
AD  
APK/  
ADK  
DryAir  
EX-  
XPLNprf  
XPLNprf  
HVB/  
HVL  
S B/  
NAB  
LAD/  
NAD  
Water-  
Rela  
NP/NAP/  
NVP  
SNP  
CHB/G  
MXB/G  
Other valves  
SWD/  
MWD  
DustColl  
CVE/  
CVSE  
CCH/  
CPE/D  
LifeSci  
Gas-  
Combus  
Auto-  
Water  
Outdoor  
SpecFld  
Custom  
Ending