



Pilot operated 2-port solenoid valve

# PVS Series

- NC (open when energized), NO (closed when energized)
- Working fluid: Steam/water/air
- Port size: Rc1/2, Rc3/4, Rc1, 32 to 80 flange



- EXA
- FWD
- HNB/G
- USB/G
- FAB/G
- FGB/G
- FVB
- FWB/G
- FHB
- FLB
- AB
- AG
- AP/AD
- APK/ADK
- DryAir
- EX-XPLNprf
- XPLNprf
- HVB/HVL
- S◇B/NAB
- LAD/NAD
- Water-Rela
- NP/NAP/NVP
- SNP
- CHB/G
- MXB/G
- Other valves
- SWD/MWD
- DustColl
- CVE/CVSE
- CCH/CPE/D
- LifeSci
- Gas-Combust
- Auto-Water
- Outdoor
- SpecFld
- Custom
- Ending

## JIS symbol

- NC (open when energized)

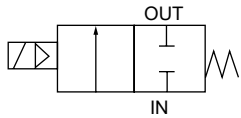

- NO (closed when energized)

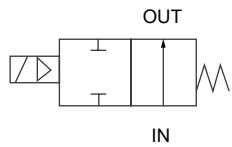

## Mounting orientation

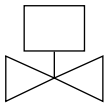

## Stable operation and long service life general purpose valve

- The use of a 3-port pilot valve enables stable operation
- Packless pipe double structure
- Short plunger stroke length
- NC (open when energized)/NO (closed when energized)

## Specifications

1 MPa ≈ 145.0 psi, 1 MPa = 10 bar

Item	PVS-15A-210	PVS-20A-210	PVS-25A-210	PVS-32A-210	PVS-40A-210	PVS-50A-210	PVS-65A-210	PVS-80A-210	
Working fluid	Steam/water/air								
Port size	Rc1/2	Rc3/4	Rc1	32 flange	40 flange	50 flange	65 flange	80 flange	
Orifice size mm	15	20	25	32	40	50	65	80	
Cv	3.1	5.4	10	22	30	48	68	100	
Max. working pressure MPa	1.0 (≈150 psi, 10 bar)								
Working pressure differential MPa	0.05 (≈7.3 psi, 0.5 bar) to 1 (≈150 psi, 10 bar)								
Proof pressure (water pressure) MPa	1.5 (≈220 psi, 15 bar)								
Fluid temperature °C	5 (41°F) to 185 (365°F)								
Ambient temperature °C	0 (32°F) to 70 (158°F)								
Valve seat leakage cm <sup>3</sup> /min	400 or less (at pneumatic pressure 0.05 to 1 MPa)						800 or less (at pneumatic pressure 0.05 to 1 MPa)		
Mounting orientation	Limited to vertical orientation with the coil on top.								
Weight kg	2.2	2.6	3.1	8.5	9.8	14.2	21.8	25.1	
<b>Electrical specifications</b>									
Rated voltage	100 VAC 50/60 Hz, 200 VAC 50/60 Hz								
Apparent power	When holding	37 [43]						85 [102]	
	When starting	130 [151]						300 [360]	
Power consumption W	29						70		
Thermal class	Class 180 (H)								

\*1 : Values in [ ] are for NO.

## How to order

**PVS** - **15A** - **210** - **4M** - **AC100V**

**A** Port size

**B** Actuation

**C** Coil option

**D** Voltage

Code	Description
<b>A Port size</b>	
<b>15A</b>	Rc1/2
<b>20A</b>	Rc3/4
<b>25A</b>	Rc1
<b>32A</b>	32 flange
<b>40A</b>	40 flange
<b>50A</b>	50 flange
<b>65A</b>	65 flange
<b>80A</b>	80 flange
<b>B Actuation</b>	
<b>Blank</b>	NC (open when energized)
<b>NO</b>	NO (closed when energized)
<b>C Coil option</b>	
<b>Blank</b>	Open frame lead wire coil
<b>4M</b>	HP terminal box (G1/2)
<b>4N</b>	HP terminal box with lamp (G1/2)
<b>D Voltage</b>	
<b>AC100V</b>	100 VAC 50/60 Hz
<b>AC200V</b>	200 VAC 50/60 Hz

\* Glands for terminal box are available. Contact CKD for details.

## Internal structure and parts list

● NC (open when energized)  
PVS-15A to 80A-210

● NO (closed when energized)  
PVS-15A to 80A-210NO

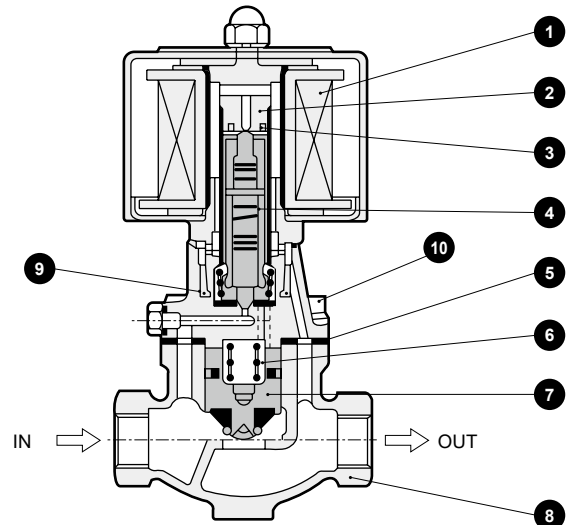
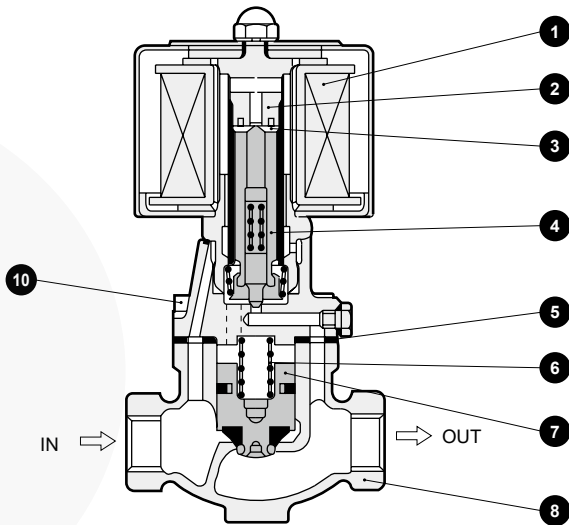

NO (closed when energized) keep the main valve open using the fluid pressure on the IN side when no current is applied.

No.	Part name	Material	No.	Part name	Material
1	Coil	—	6	Spring *1	SUS304 : Stainless steel
2	Core assembly	SUS405 or equiv. : Stainless steel	7	Main valve	SUS304/PTFE : Stainless steel Tetrafluoroethylene resin
3	Shading coil	C1100T : Copper	8	Body	CAC408 : Bronze casting
4	Plunger	SUS405 or equiv. : Stainless steel	9	O-ring	FKM : Fluoro rubber
5	Gasket	PTFE : Tetrafluoroethylene resin	10	Bolt	SWRM : Steel

\*1 : A spring is not available for 50A to 80A.

\*2 : After an entire day of use, tighten the bolt again.

## Dimensions

● PVS-15A to 25A-210

● PVS-32A to 80A-210

● PVS-80A-210

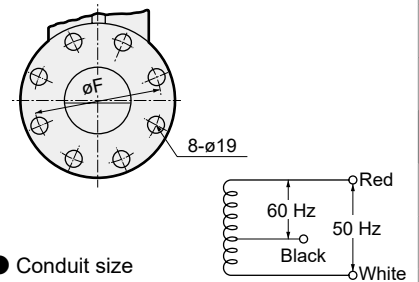
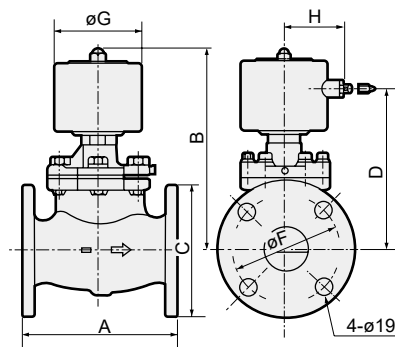
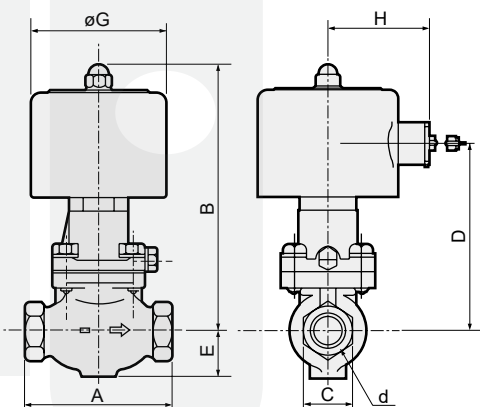

● Conduit size  
Thin steel conduit thread  
JIS C 8305 CTC19

● Lead wire

30/0.18 (0.75 mm<sup>2</sup>) silicone rubber insulated glass fiber braided wire

Length 300 mm

\* d is the port size (refer to the left page).

Model No.	A	B	C	D	E	F	G	H
PVS-15A-210	90	152	29	107	27	—	84	61
PVS-20A-210	100	159	35	114	31	—	84	61
PVS-25A-210	110	170	46	125	33	—	84	61
PVS-32A-210	170	181	135	136	—	100	84	61
PVS-40A-210	180	191	140	146	—	105	84	61
PVS-50A-210	180	237	155	177	—	120	100	69
PVS-65A-210	210	263	175	203	—	140	100	69
PVS-80A-210	240	290	185	230	—	150	100	69