



Oil mist filter Standard White Series

# M1000/M2000/M3000 M4000/M6000/M8000-W Series

Ideal for circuits susceptible to oil, including measuring, and instrumentation circuits.

● Port size: 1/8 to 1

JIS symbol



## Specifications

Item	M1000-W	M2000-W	M3000-W	M4000-W	M6000-W	M8000-W
Appearance						
Working fluid	Compressed air					
Working pressure MPa	0.1 (≈15 psi, 1 bar) to 1.0 (≈150 psi, 10 bar) *2, *3					
Proof pressure MPa	1.5 (≈220 psi, 15 bar) *2					
Drain capacity cm <sup>3</sup>	3	25	45	80	80	80
Port size Rc,NPT,G	1/8, 1/4 (3/8 uses an adaptor)	1/4, 3/8 (1/2 uses an adaptor)		1/4, 3/8, 1/2 (3/4 uses an adaptor)	3/4, 1 (1 1/4 uses an adaptor)	3/4, 1 (1 1/4 uses an adaptor)
Weight kg	0.096	0.25	0.28	0.52	0.95	1.35
Standard accessories	Bowl guard					

Mantle option name	Blank (M type)	S (S type)	X (X type)
Max. processing flow rate	150 *2	150 *2	150
flow rate ℓ /min(ANR)	M1000-□-W	250	310
	M2000-□-W	360	450
	M3000-□-W	825	1000
	M4000-□-W	1400	1400
Primary pressure 0.7 MPa	M6000-□-W	2900	2900
	M8000-□-W		
Ambient / fluid temperatures °C	5 to 60		5 to 30
Filtration rating μm	0.01 (nominal)		Suction by activated charcoal
Secondary side oil concentration mg/m <sup>3</sup>	≤0.01 (≤0.1 after oil saturation) *4, 5		0.5 or less *4
Mantle (element) change	1 year (6000 hours) or pressure drop 0.1 MPa		0.003 or less *6
			- *7

\*1: Use within the max. processing flow rate.

If the max. processing flow rate is exceeded temporarily, or if the filter is installed at a location with high levels of pulsation, the mantle could be damaged or oil or drainage, etc., could splatter to the secondary side and result in a terminal malfunction.

\*2: When using M1000-W-F1 auto-drain, the min. working pressure is 0.2 MPa, the max. working pressure is 0.7 MPa and the proof pressure is 1.05 MPa. For the max. processing flow rate, refer to the max. processing flow rate graph (page 119).

\*3: In the case of "F1" with auto-drain, the min. working pressure is 0.15 MPa.

\*4: The secondary oil concentration is the value when the primary oil concentration is 30 mg/m<sup>3</sup> and inlet air temperature is 21°C.

\*5: Install an oil mist filter (S type) as a pre-filter on the primary side to prevent early clogging.

\*6: When an oil mist filter (M Series M type) is installed on the primary side.

\*7: The mantle (element) replacement period differs depending on the odor density in compressed air, and thus cannot be clearly indicated.

Consider the total period from initial installation to when the smell of oil is confirmed as the effective deodorizing period, and replace at the same time as the M type or control with usage time. (When the inlet temperature is 21°C, replace at the control time or 1,000 hours, whichever is sooner)

Keep the primary air temperature at 30°C or less. The deodorizing effect will drop if temperature is high, so provide heat dissipation measures.

F.R.L.  
F.R.  
F (Filtr)  
R (Reg)  
L (Lub)  
Drain Separ  
Mech Press SW  
Res press exh valve  
SlowStart  
Anti-bac/Bac-removal Filtr  
Film Resist FR  
Oil-ProHR  
Med Press FR  
No Cu/PTFE FRL  
Outdrs FRL  
Adapter Joiner Press Gauge  
CompFRL  
LgFRL  
PrecsR  
VacF/R  
Clean FR  
ElecPneUR  
AirBoost  
Speed Ctrl  
Silncr  
CheckV/other  
Fit/Tube  
Nozzle  
Air Unit  
PrecsCompn  
Electro Press SW  
ContactSW  
AirSens  
PresSW Cool  
Air Flo Sens/Ctrl  
WaterRiSens  
TotAirSys (Total Air)  
TotAirSys (Gamma)  
Gas generator  
RefrDry  
DesicDry  
HiPolymDry  
MainFiltr  
Dischrg etc  
Ending

# Oil Mist Filter series

Differential pressure switch/Switch specifications, option weight list

## Differential pressure switch/Switch specifications

Differential pressure switch option name	Differential pressure switch option Q3/Q4	
	Reed 2-wire	
Load voltage	12/24 VDC	110 VAC
Load current *1	5 to 50 mA	7 to 20 mA
Internal voltage drop	3 V or less	
Display lamp	Red LED (Lit when ON)	
Lead wire length	3 m (oil resistant vinyl cable 2-conductor 0.2 mm <sup>2</sup> )	
Impact resistance	294 m/s <sup>2</sup>	
Insulation resistance	20 MΩ and over with 500 VDC megger	
Withstand voltage	No failure after 1 minute of 1,000 VAC application	
Degree of protection	IEC Standard IP67, JIS C0920 (water-tight), oil resistance	
Contact protection circuit	None	

\*1: Install a load resistor before use.

### CE marking specifications

Compatible as standard.

### Switch internal circuit diagram

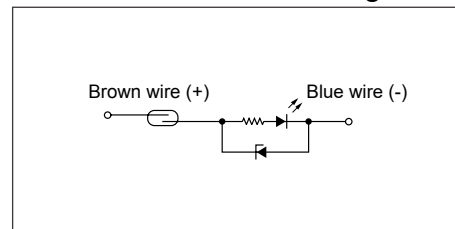

## Option weight

\* Add to the weight of the standard accessories.

Unit: kg

Code	Drain discharge	Bowl material			Differential pressure indicator		Differential pressure switch		Pipe adaptor set						Bracket
	F1	M	M1	Q1	Q2	Q3	Q4	A6*W	A8*W	A10*W	A15*W	A20*W	A25*W	A32*W	BW
M1000	0.007							0.09	0.09	0.09					0.1
M2000	0.02		0.1		0.04	0.09	0.13		0.16	0.16	0.16				0.15
M3000	0.02	0.1	0.1		0.04	0.09	0.13		0.16	0.16	0.16				0.17
M4000	0.02	0.1	0.1	0.024	0.05	0.10	0.14		0.16	0.16	0.16	0.16			0.21
M6000	0.02	0.1	0.1		0.05	0.10	0.14					0.53	0.53	0.53	0.34
M8000	0.02	0.1	0.1									0.53	0.53	0.53	0.36

### Clean-room specifications (Catalog No. CB-033SA)

- Anti-dust generation structure for use in cleanrooms

M\*000 - ..... - P7\*

### Specifications for rechargeable battery (Catalog No. CC-1226A)

- Design compatible with rechargeable battery manufacturing process

M\*000 - ..... - P4\*

F.R.L.
F.R.
F (Filtr)
R (Reg)
L (Lub)
Drain Separ
Mech Press SW
Res press exh valve
SlowStart
Anti-bac/Bac-remove Filtr
Film Resist FR
Oil-ProhR
Med Press FR
No Cu/ PTFE FRL
Outdrs FRL
Adapter Joiner
Press Gauge
CompFRL
LgFRL
PreclsR
VacF/R
Clean FR
ElecPneuR
AirBoost
Speed Ctrl
Silncr
CheckV/ other
Fit/Tube
Nozzle
Air Unit
PreclsCompn
Electro Press SW
ContactSW
AirSens
PresSW Cool
Air Flo Sens/Ctrl
WaterRISens
TotAirSys (Total Air)
TotAirSys (Gamma)
Gas generator
RefrDry
DesicDry
HiPolymDry
MainFiltr
Dischrg etc
Ending

# Oil Mist Filter Series

## F.R.L. How to order

F.R. **M1000** - **6** - **W** - **S** - **A6W**

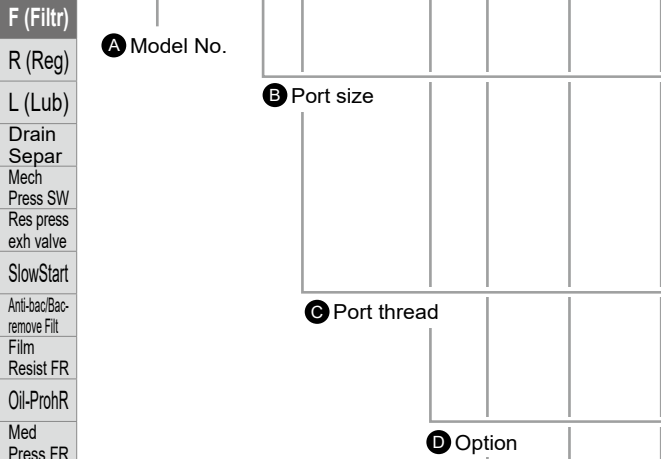

- F (Filtr)
- R (Reg)
- L (Lub)
- Drain Separ
- Mech Press SW
- Res press exh valve
- SlowStart
- Anti-bac/Bac-remove Filt
- Film Resist FR
- Oil-Prohr
- Med Press FR
- No Cu/ PTFE FRL
- Outdrs FRL
- Adapter Joiner Press Gauge
- CompFRL
- LgFRL
- PrecsR
- VacF/R
- Clean FR
- ElecPneur
- AirBoost
- Speed Ctrl
- Silncr
- CheckV/ other
- Fit/Tube
- Nozzle
- Air Unit
- PrecsCompn
- Electro Press SW
- ContactSW
- AirSens
- PresSW Cool
- Air Flo Sens/Ctrl
- WaterRiSens
- TotAirSys (Total Air)
- TotAirSys (Gamma)
- Gas generator
- RefrDry
- DesicDry
- HiPolymDry
- MainFiltr
- Dischrg etc
- Ending

\* Refer to page 30 for the explanation of the options.

### A Model No.

Code	Description	M1000	M2000	M3000	M4000	M6000	M8000
<b>B Port size</b>							
<b>6</b>	1/8	●					
<b>8</b> *1	1/4	●	●	●	●		
<b>10</b>	3/8		●	●	●		
<b>15</b>	1/2				●		
<b>20</b>	3/4					●	●
<b>25</b>	1					●	●
<b>C Port thread</b> *2							
<b>Blank</b>	Rc thread	●	●	●	●	●	●
<b>N</b>	NPT thread	●	●	●	●	●	●
<b>G</b>	G thread	●	●	●	●	●	●
<b>D Option</b> *3							
Drain *4,5 Discharge	<b>Blank</b>	With manual drain cock		●	●	●	●
	<b>F1</b>	Auto-drain with man/override (NC: No press → no exhaust)		●	●	●	●
Bowl Material	<b>Blank</b>	Polycarbonate bowl		●	●	●	●
	<b>Z</b>	Nylon bowl		●	●	●	●
	<b>M</b>	Metal bowl *6			●	●	●
	<b>M1</b>	Metal bowl with manual drain cock			●	●	●
Mantle (Element)	<b>Blank</b>	M type (nominal 0.01 μm; remaining oil 0.01 mg/m <sup>3</sup> )		●	●	●	●
	<b>S</b>	S type (0.3 μm; remaining oil 0.5 mg/m <sup>3</sup> )		●	●	●	●
	<b>X *6</b>	X type (deodorization; remaining oil 0.003 mg/m <sup>3</sup> )		●	●	●	●
Diff press Detect	<b>Blank</b>	Without differential pressure detection port		●	●	●	●
	<b>Q</b>	With differential pressure detection port (Rc1/4)				●	●
Differential pressure indicator	<b>Blank</b>	No differential pressure indicator		●	●	●	●
	<b>Q1 *7</b>	With differential pressure indicator *8				●	
	<b>Q2</b>	With differential pressure indicator			●	●	●
Diff press SW	<b>Q3</b>	Differential pressure indicator + switch 1-point (SW2)			●	●	●
	<b>Q4</b>	Differential pressure indicator + switch 2-point (SW1/SW2)			●	●	●
Flow Direction	<b>Blank</b>	Standard flow (left → right)		●	●	●	●
	<b>X1</b>	Reverse flow (right → left)		●	●	●	●
<b>E Display unit</b>							
<b>Blank</b>	MPa display (Rc thread), psi display (NPT thread), bar display (G thread)		●	●	●	●	●
<b>J1</b>	MPa display (NPT, G threads)		●	●	●	●	●
<b>F Pipe adaptor set (included)</b> *8 *9 page 350							
<b>Blank</b>	Not included		●	●	●	●	●
<b>A6*W</b>	1/8 pipe adaptor set		●				
<b>A8*W</b>	1/4 pipe adaptor set		●	●	●		
<b>A10*W</b>	3/8 pipe adaptor set		●	●	●		
<b>A15*W</b>	1/2 pipe adaptor set			●	●		
<b>A20*W</b>	3/4 pipe adaptor set				●	●	●
<b>A25*W</b>	1 pipe adaptor set					●	●
<b>A32*W</b>	1 1/4 pipe adaptor set					●	●
<b>* Adaptor thread</b>							
<b>Blank</b>	Rc thread		●	●	●	●	●
<b>N</b>	NPT thread		●	●	●	●	●
<b>G</b>	G thread		●	●	●	●	●
<b>G Bracket (included)</b> Page 346							
<b>Blank</b>	Not included		●	●	●	●	●
<b>BW</b>	C-bracket		●	●	●	●	●

### ⚠ Precautions for model No. selection

- \*1: "Q1" with differential pressure indicator and "Q3" "Q4" differential pressure switch cannot be selected for port size "8".
- \*2: G threads and NPT threads are available for IN, OUT and drain outlet (metal bowl with auto-drain).
- \*3: Select options for drainage, bowl material and differential pressure detection. When selecting options for several items, list options in order from the top.
- \*4: NO auto-drain cannot be selected.
- \*5: Refer to page 354 for the auto-drain usage conditions.
- \*6: "X" mantle cannot be combined with F1 option or "Q1" (with differential pressure indicator).
- \*7: "Q1" with differential pressure indicator cannot be selected for bowl material "M".
- \*8: The pipe adaptor set and C type bracket cannot be used together.
- \*9: The joiner set is included with the pipe adaptor set.

- E** Display unit
- F** Pipe adaptor set (included)
- G** Bracket (included)

### D Options: Differential pressure indicator/differential pressure switch

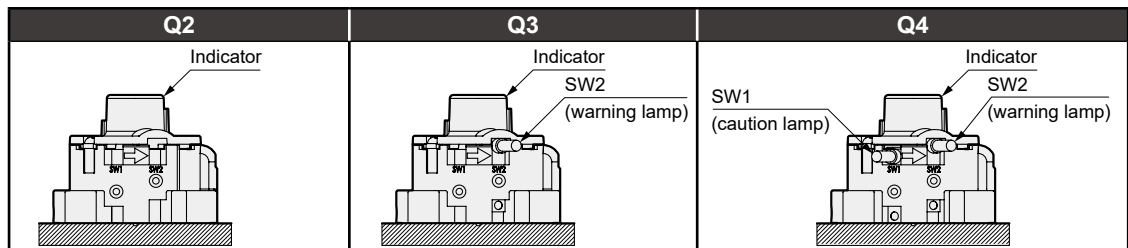

# Oil Mist Filter series

Flow characteristics (max. processing flow rate)

## Flow characteristics (max. processing flow rate)

● M\*000-W-M

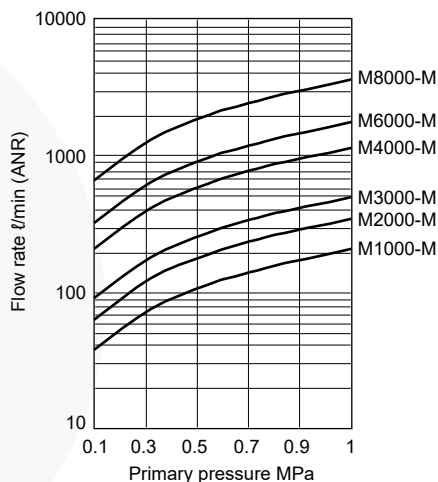

● M\*000-W-S

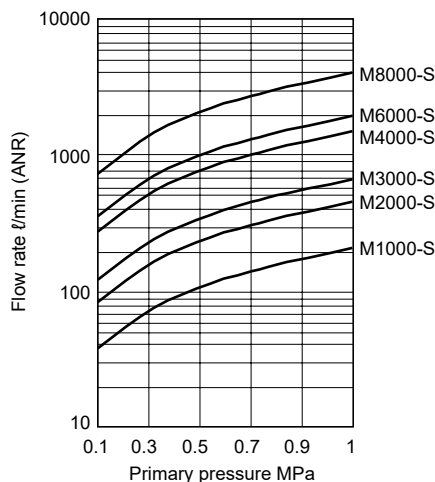

● M\*000-W-X

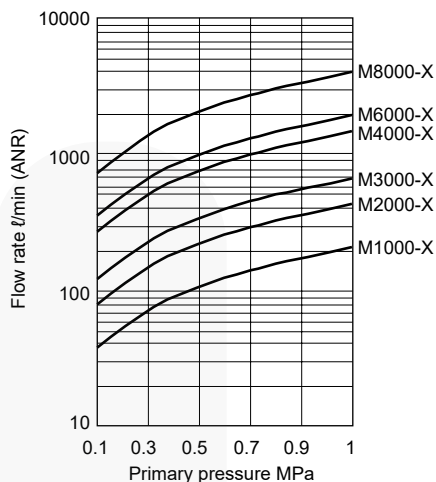

● M1000-W-F1

With auto-drain (M type, S type)

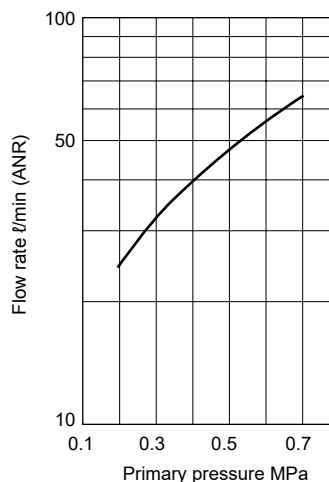

## How to select oil mist filter and optional mantle

Recommended circuit

◆ S type



- Applications  
General industrial air
- Air tool
    - Air drill/air screw driver
    - Pneumatic grinder
  - Labor-saving device
  - Pneumatic jigs and tools
  - Air chuck
  - Air vice
  - Precision part cleaning air blow

◆ M type



- Oil-free air
- Instrumentation
  - Measurement
  - For sequence control
  - Movable element/pure fluid element
  - Luxury painting
  - Precision industry

◆ X type



- Odorless air
- Food industry
  - Pharmaceutical industry
  - Mixing
  - Transportation
  - Drying
  - Packaging
  - Brewing air

## Option code of mantle and shape

Option code	Appearance
Blank (M type)	<p>End plate black Plastic foam</p>
S (S type)	<p>End plate green Plastic foam</p>
X (X type)	<p>End plate black Perforated metal</p>

Note: Changes for product upgrades may be made without prior notice.  
When placing an order, confirm the option code of the part model No. displayed on the body.

- F.R.L.
- F.R.
- F (Filtr)**
- R (Reg)
- L (Lub)
- Drain Separ
- Mech Press SW
- Res press exh valve
- SlowStart
- Anti-bac/Bac-remove Filtr
- Film Resist FR
- Oil-ProhR
- Med Press FR
- No Cu/ PTFE FRL
- Outdrs FRL
- Adapter Joiner
- Press Gauge
- CompFRL
- LgFRL
- PrecsR
- VacF/R
- Clean FR
- ElecPneuR
- AirBoost
- Speed Ctrl
- Silncr
- CheckV/ other
- Fit/Tube
- Nozzle
- Air Unit
- PrecsCompn
- Electro Press SW
- ContactSW
- AirSens
- PresSW Cool
- Air Flo Sens/Ctrl
- WaterR/Sens
- TotAirSys (Total Air)
- TotAirSys (Gamma)
- Gas generator
- RefrDry
- DesicDry
- HiPolymDry
- MainFiltr
- Dischrg etc
- Ending

# Oil Mist Filter Series

## F.R.L. Internal structure and parts list

F.R.

● M1000-W

● M2000-W

● M3000-W/M4000-W

F (Filtr)

R (Reg)

L (Lub)

Drain

Separ

Mech

Press SW

Res press

exh valve

SlowStart

Anti-bac/Bac-

remove Filtr

Film

Resist FR

Oil-ProhR

Med

Press FR

No Cu/

PTFE FRL

Outdrs FRL

Adapter

Joiner

Press

Gauge

CompFRL

LgFRL

PrecsR

VacF/R

Clean FR

ElecPneuR

AirBoost

Speed Ctrl

Silncr

CheckV/

other

Fit/Tube

Nozzle

Air Unit

PrecsCompn

Electro

Press SW

ContactSW

AirSens

PresSW

Cool

Air Flo

Sens/Ctrl

WaterRiSens

TotAirSys

(Total Air)

TotAirSys

(Gamma)

Gas

generator

RefrDry

DesiccDry

HiPolymDry

MainFiltr

Dischrg

etc

Ending

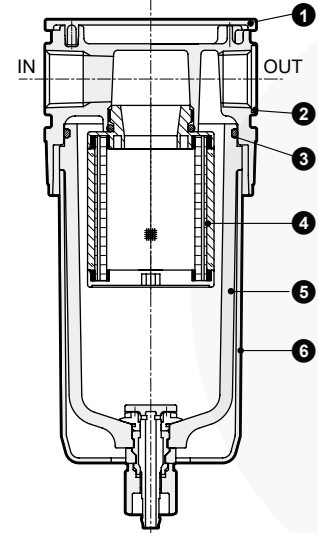
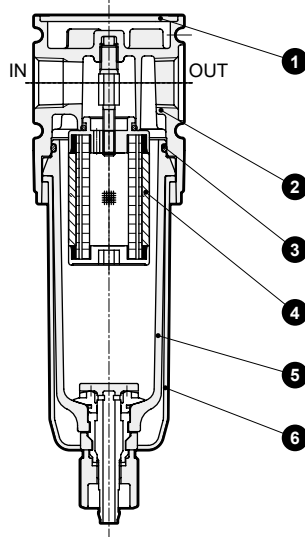
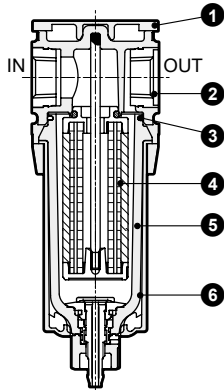

● M6000-W

● M8000-W

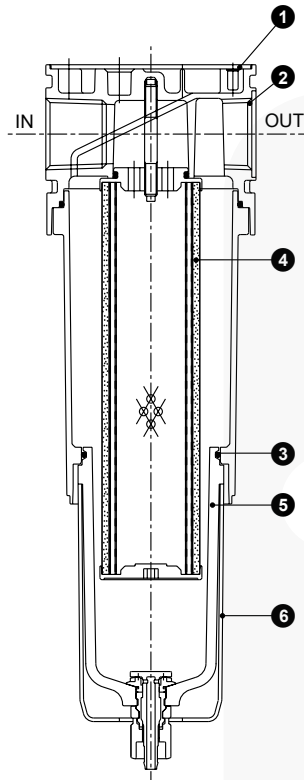
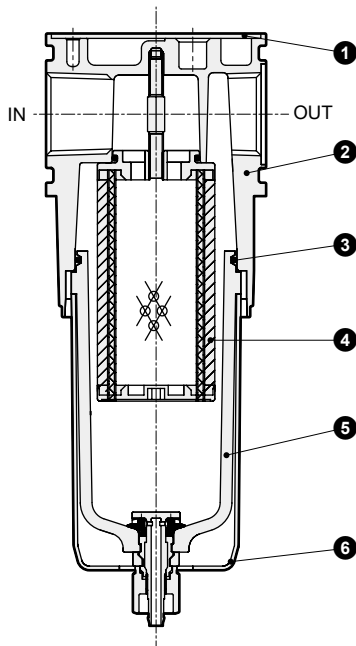

No.	Part name	Material					
		M1000-W	M2000-W	M3000-W	M4000-W	M6000-W	M8000-W
1	Plate cover	ABS resin					
2	Body	Polyamide resin	Aluminum alloy die-casting				
3	O-ring *1	Special nitrile rubber					
4	Mantle assembly	-					
5	Bowl assembly	Polycarbonate resin, polyacetal resin, urethane resin					
6	Bowl guard	Polyamide resin	Polyamide resin, steel				

\*1: The O-ring of the M1000-W has a special shape.

### Dimensions



#### ● M1000-W

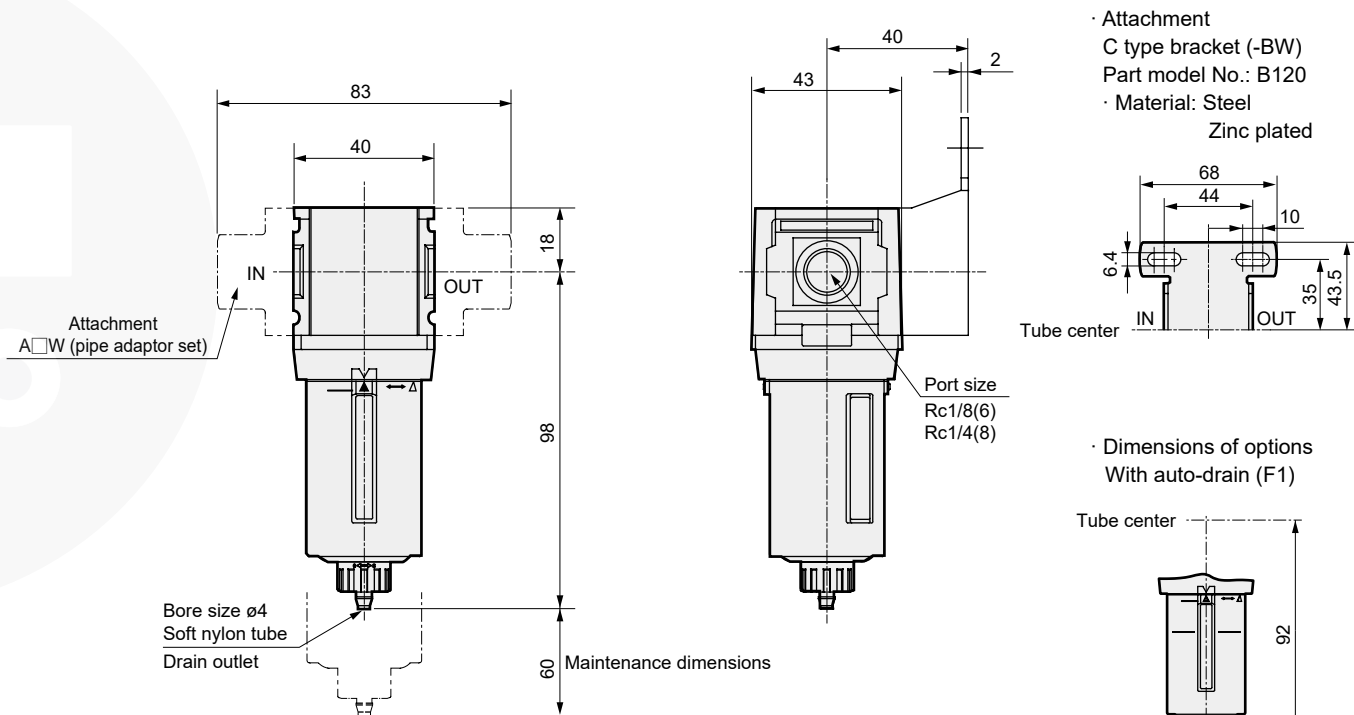

#### ● M2000-W

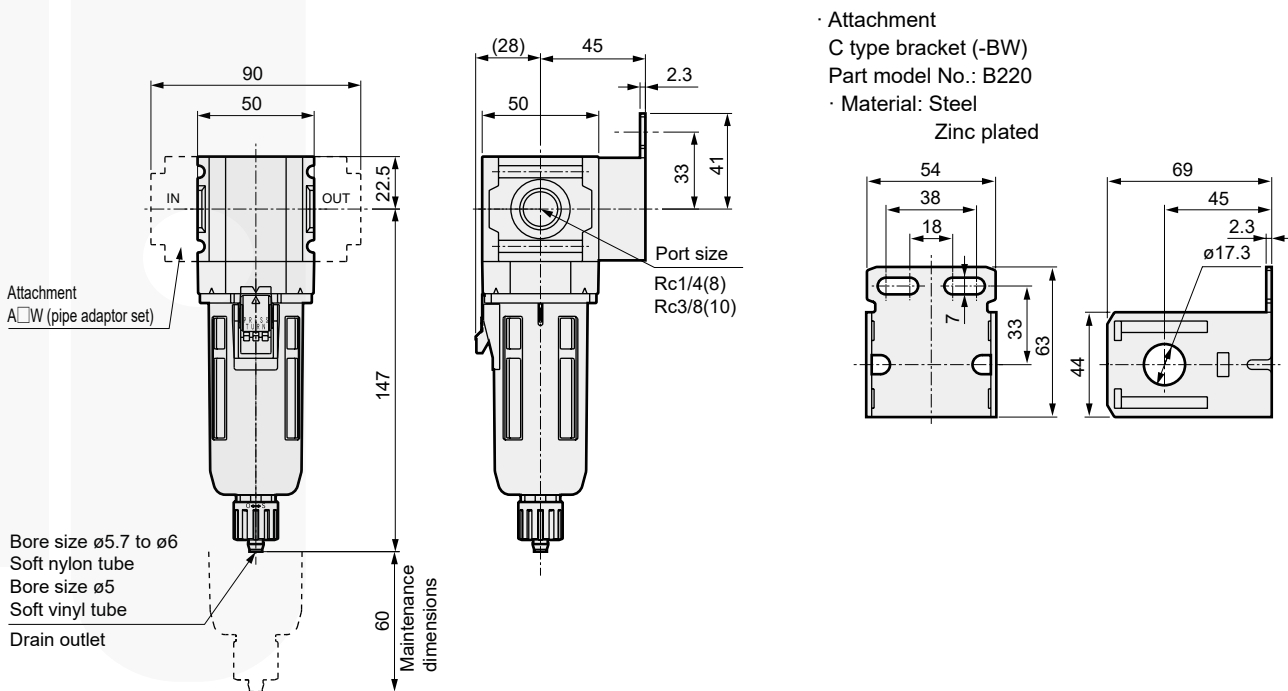

F.R.L.
F.R.
F (Filtr)
R (Reg)
L (Lub)
Drain Separ
Mech Press SW
Res press exh valve
SlowStart
Anti-bac/Bac-remove Filtr
Film Resist FR
Oil-ProhR
Med Press FR
No Cu/ PTFE FRL
Outdrs FRL
Adapter Joiner Press Gauge
CompFRL
LgFRL
PrecsR
VacF/R
Clean FR
ElecPneuR
AirBoost
Speed Ctrl
Silncr
CheckV/ other
Fit/Tube
Nozzle
Air Unit
PrecsCompn
Electro Press SW
ContactSW
AirSens
PresSW Cool
Air Flo Sens/Ctrl
WaterRISens
TotAirSys (Total Air)
TotAirSys (Gamma)
Gas generator
RefrDry
DesicDry
HiPolymDry
MainFiltr
Dischrg etc
Ending

# Oil Mist Filter Series

F.R.L.
F.R.
<b>F (Filtr)</b>
R (Reg)
L (Lub)
Drain Separ
Mech Press SW
Res press exh valve
SlowStart
Anti-bac/Bac-remove Filt
Film Resist FR
Oil-ProhR
Med Press FR
No Cu/PTFE FRL
Outdrs FRL
Adapter Joiner
Press Gauge
CompFRL
LgFRL
PrecsR
VacF/R
Clean FR
ElecPneuR
<b>AirBoost</b>
Speed Ctrl
<b>Silncr</b>
CheckV/other
Fit/Tube
Nozzle
Air Unit
PrecsCompn
Electro Press SW
ContactSW
AirSens
PresSW Cool
Air Flo Sens/Ctrl
WaterR/Sens
TotAirSys (Total Air)
TotAirSys (Gamma)
Gas generator
RefrDry
DesicDry
HiPolymDry
MainFiltr
Dischrg etc
Ending

## Dimensions



● M3000-W

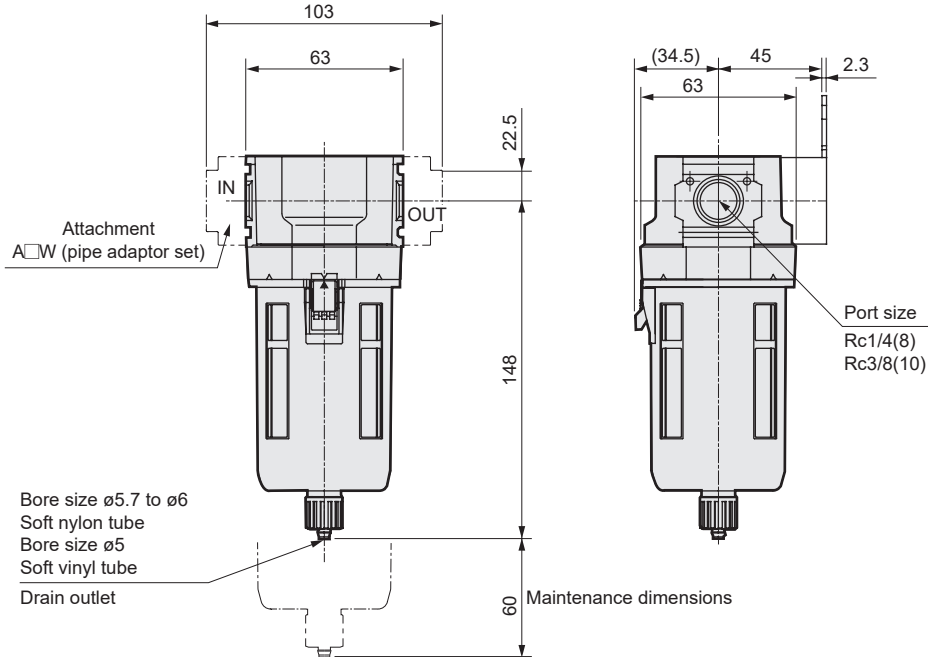

· Attachment  
C type bracket (-BW)  
Part model No.: B320  
· Material: Steel  
Zinc plated

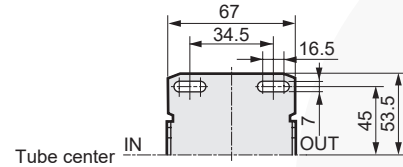

● For the plastic bowl, the dimensions of the manual cock and the auto-drain are the same.  
Note: The C type bracket and pipe adaptor set attachments cannot be used together.

● M4000-W

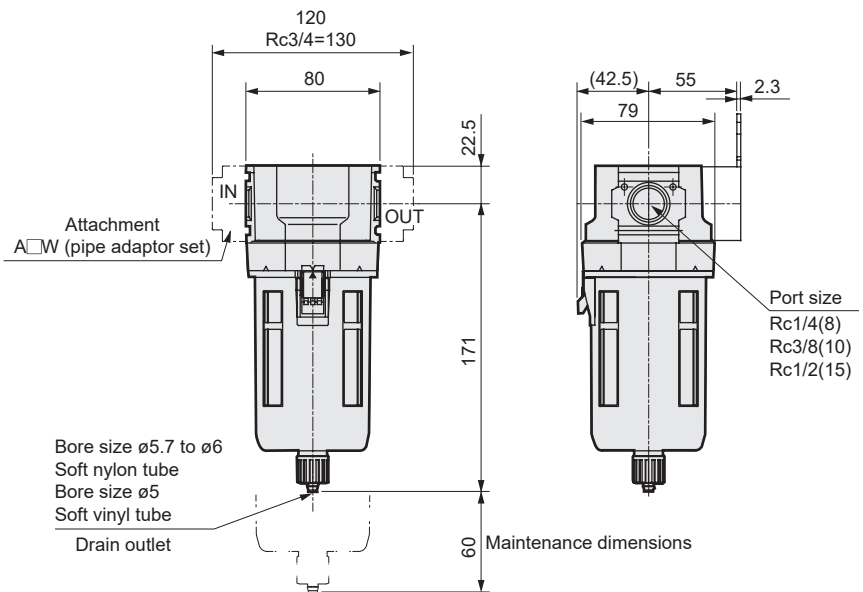

· Attachment  
C type bracket (-BW)  
Part model No.: B420  
· Material: Steel  
Zinc plated

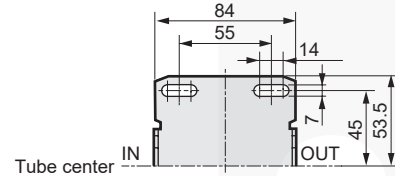

· Dimensions of options  
With differential pressure indicator (Q1)

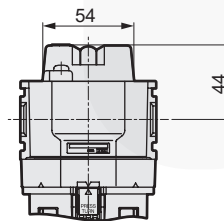
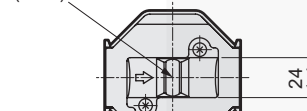

(Note): Normally green, and red when replacing the element



### Dimensions

● M6000-W

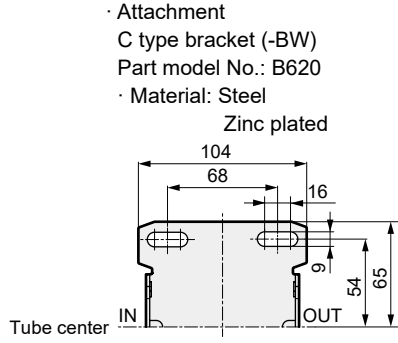
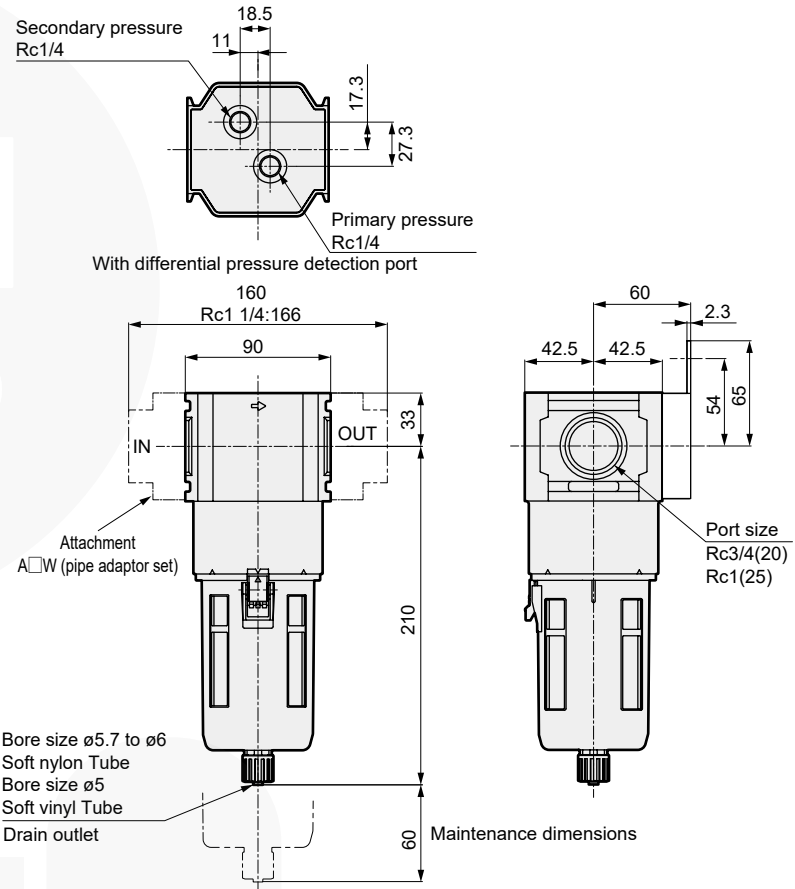

● For the plastic bowl, the dimensions of the manual cock and the auto-drain are the same.  
Note: The C type bracket and pipe adaptor set attachments cannot be used together.

● M8000-W

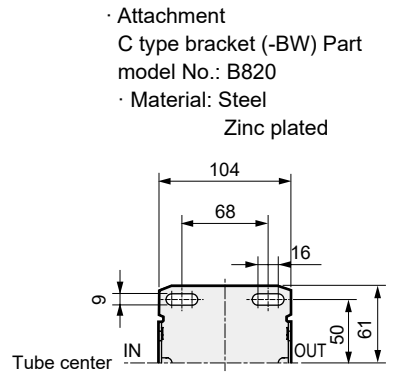
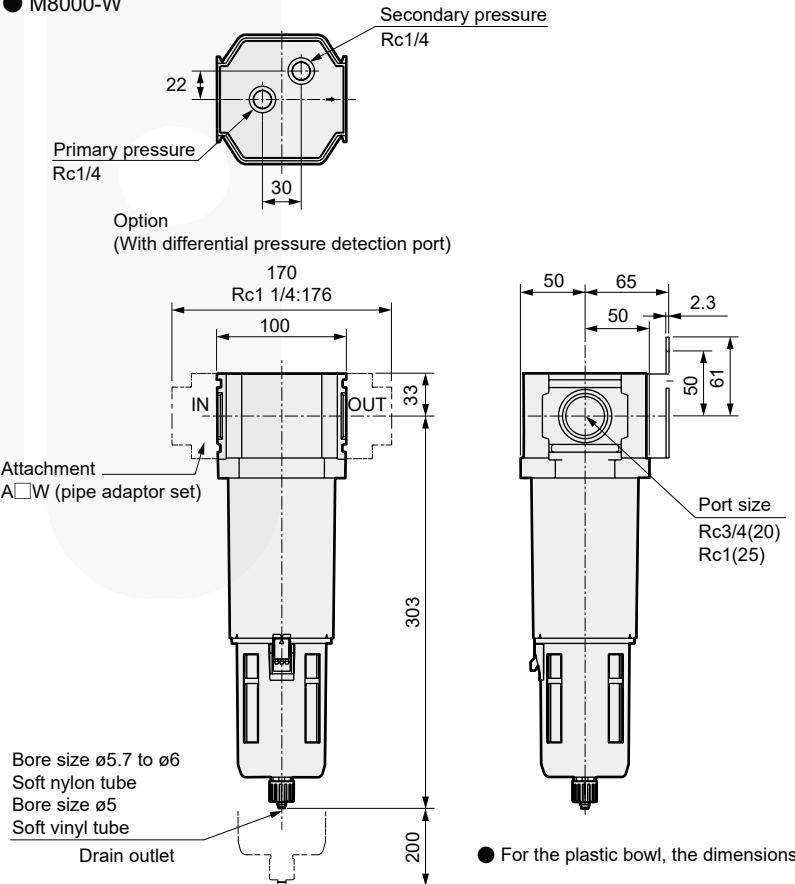

● For the plastic bowl, the dimensions of the manual cock and the auto-drain are the same.

F.R.L.
F.R.
F (Filtr)
R (Reg)
L (Lub)
Drain Separ
Mech Press SW
Res press exh valve
SlowStart
Anti-bac/Bac-remove Filtr
Film Resist FR
Oil-ProhR
Med Press FR
No Cu/ PTFE FRL
Outdrs FRL
Adapter Joiner Press Gauge
CompFRL
LgFRL
PrecsR
VacF/R
Clean FR
ElecPneuR
AirBoost
Speed Ctrl
Silncr
CheckV/ other
Fit/Tube
Nozzle
Air Unit
PrecsCompn
Electro Press SW
ContactSW
AirSens
PresSW Cool
Air Flo Sens/Ctrl
WaterRISens
TotAirSys (Total Air)
TotAirSys (Gamma)
Gas generator
RefrDry
DesicDry
HiPolymDry
MainFiltr
Dischrg etc
Ending



# Oil Mist Filter Series



## F.R.L. Optional dimensions

- Metal bowl (option)  
[M2000-W, M3000-W, M4000-W, M6000-W, M8000-W]

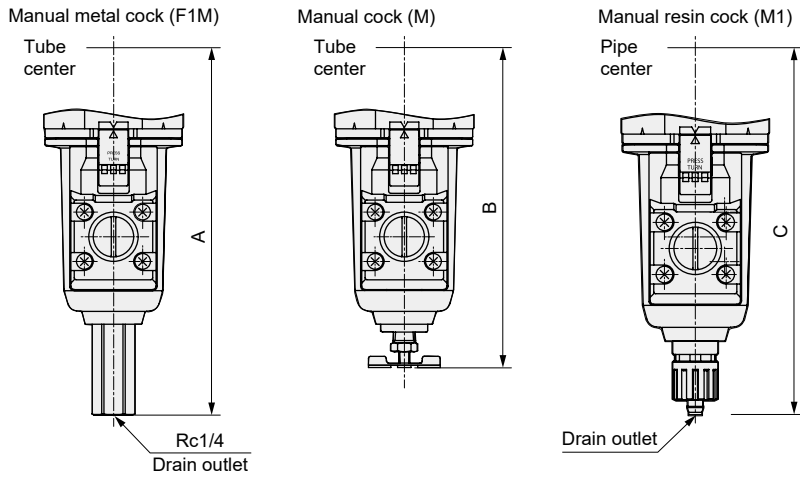

## Dimensions table

Model No.	F1M	M	M1
	A	B	C
M2000-W	-	-	147
M3000-W	164	143.5	154
M4000-W	187	166.5	177
M6000-W	226	205	216
M8000-W	319	298	309

- Material of the metal bowl is aluminum die-casting.

- With differential pressure indicator, differential pressure switch (options)  
(M2000-W, M3000-W, M4000-W, M6000-W)

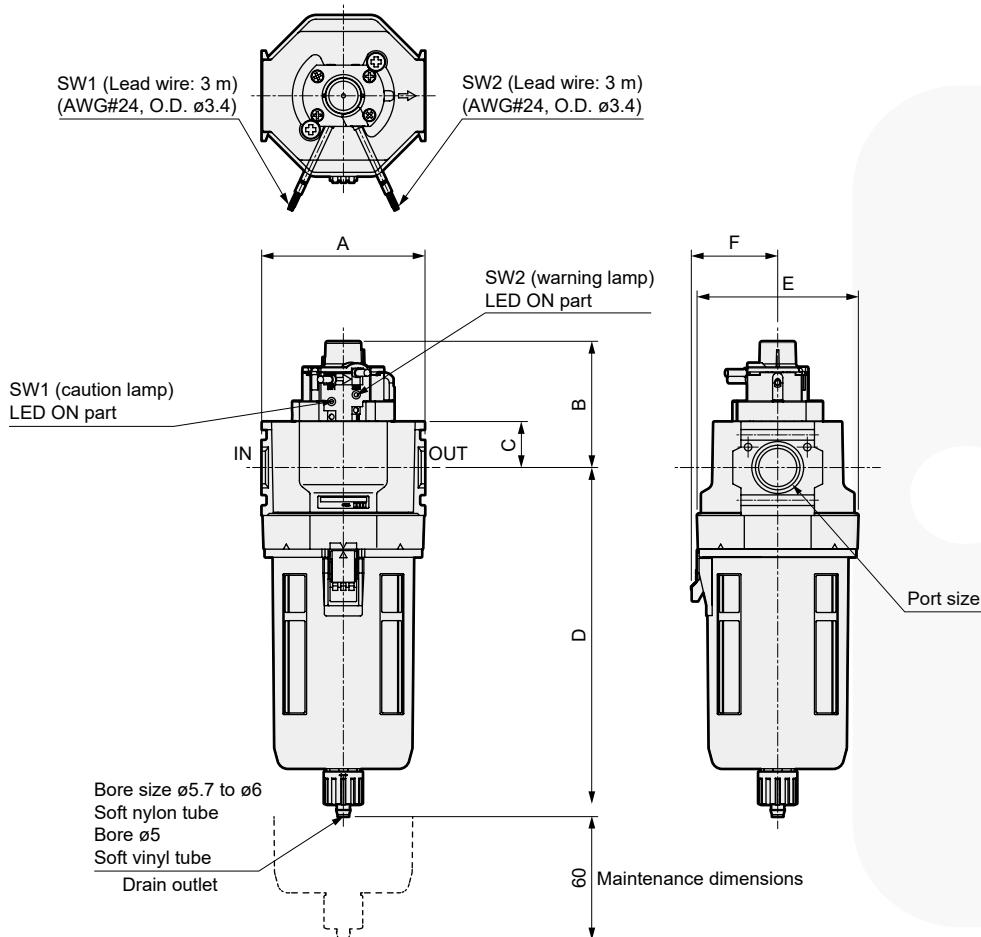

- The dimensions of the manual cock and the auto-drain are the same.  
Note: The C type bracket and piping adapter set attachments cannot be used together.

Code	Port size	A	B	C	D	E	F
M2000-W	Rc1/4(8), Rc3/8(10)	50	62	22.5	147	50	(28)
M3000-W	Rc1/4(8), Rc3/8(10)	63	62	22.5	148	63	(34.5)
M4000-W	Rc3/8(10), Rc1/2(15)	80	62	22.5	171	79	(42.5)
M6000-W	Rc3/4(20), Rc1(25)	90	72.5	33	210	85	42.5

### Optional parts list - for oil mist filters

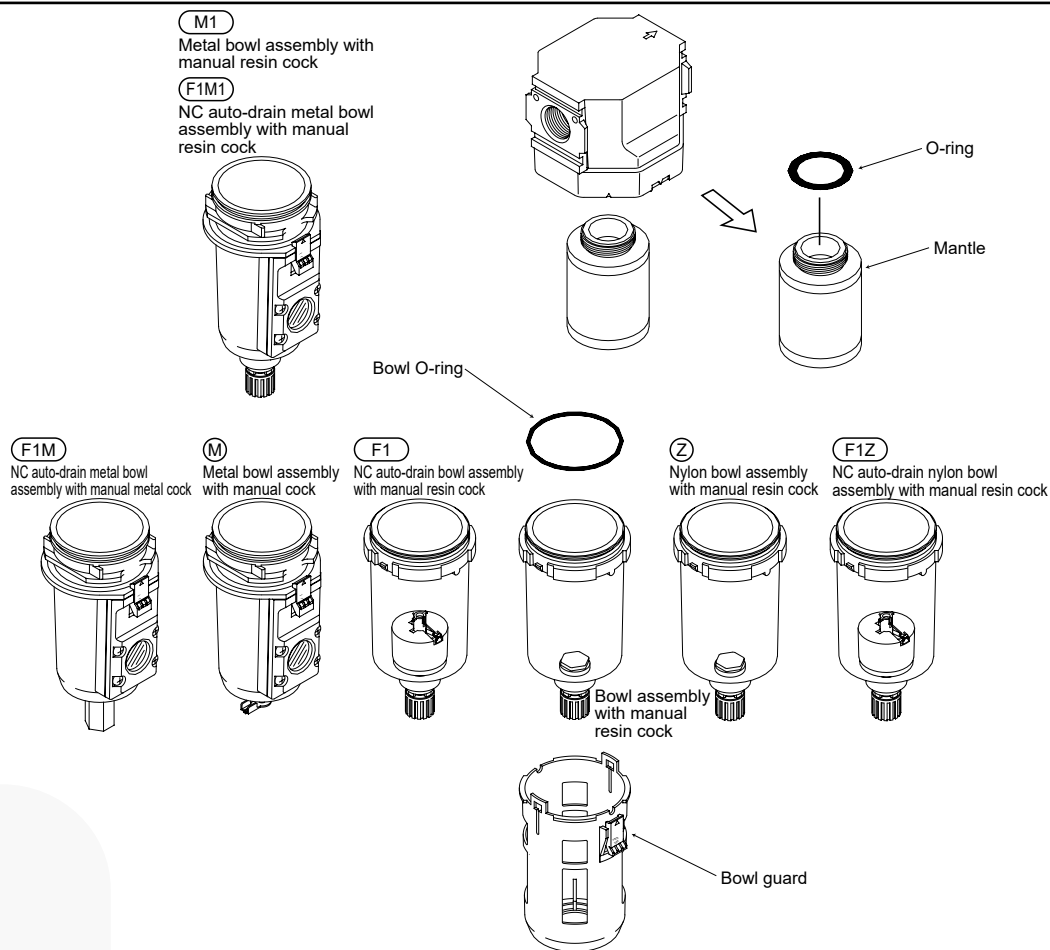

### Repair parts kit model No. (set including O-ring, mantle and bowl O-ring)

Model	M type	S type	X type
M1000-W	M1000-KIT	M1000-KIT-S	M1000-KIT-X
M1000-W-F1	M1000-KIT-F1	M1000-KIT-F1S	-
M2000-W	M2000-KIT	M2000-KIT-S	M2000-KIT-X
M3000-W,MM3000-W	M3000-KIT	M3000-KIT-S	M3000-KIT-X
M4000-W,MM4000-W	M4000-KIT	M4000-KIT-S	M4000-KIT-X
M6000-W,MM6000-W	M6000-KIT	M6000-KIT-S	M6000-KIT-X
M8000-W,MM8000-W	M8000-KIT	M8000-KIT-S	M8000-KIT-X

### Repair parts kit model No. (set including O-ring and mantle)

Model	M type	S type	X type
M1000-W	M1000-MANTLE-ASSY	M1000-MANTLE-ASSY-S	M1000-MANTLE-ASSY-X
M1000-W-F1	M1000-MANTLE-ASSY-F1	M1000-MANTLE-ASSY-F1S	-
M2000-W	M2000-MANTLE-ASSY	M2000-MANTLE-ASSY-S	M2000-MANTLE-ASSY-X
M3000-W,MM3000-W	M3000-MANTLE-ASSY	M3000-MANTLE-ASSY-S	M3000-MANTLE-ASSY-X
M4000-W,MM4000-W	M4000-MANTLE-ASSY	M4000-MANTLE-ASSY-S	M4000-MANTLE-ASSY-X
M6000-W,MM6000-W	M6000-MANTLE-ASSY	M6000-MANTLE-ASSY-S	M6000-MANTLE-ASSY-X
M8000-W,MM8000-W	M8000-MANTLE-ASSY	M8000-MANTLE-ASSY-S	M8000-MANTLE-ASSY-X

\* M parts should be selected as they are compatible with M1000-W, 3000-W, 4000-W, and 8000-W Series products released before May 1998.

\* Refer to the air filter options and parts table for details on the bowl assembly and bowl guard.

F.R.L.
F.R.
F (Filtr)
R (Reg)
L (Lub)
Drain Separ
Mech Press SW
Res press exh valve
SlowStart
Anti-bac/Bac-remove Filtr
Film Resist FR
Oil-ProHR
Med Press FR
No Cu/ PTFE FRL
Outdrs FRL
Adapter Joiner Press Gauge
CompFRL
LgFRL
PrecsR
VacF/R
Clean FR
ElecPneuR
AirBoost
Speed Ctrl
Silncr
CheckV/ other
Fit/Tube
Nozzle
Air Unit
PrecsCompn
Electro Press SW
ContactSW
AirSens
PresSW Cool
Air Flo Sens/Ctrl
WaterRISens
TotAirSys (Total Air)
TotAirSys (Gamma)
Gas generator
RefrDry
DesicDry
HiPolymDry
MainFiltr
Dischrg etc
Ending