

Auxiliary components
Piping adaptor

A400/A800 Series

Port size: Rc1/4 to Rc11/4



- SCPD3
- SCM
- SSD2
- MDC2
- SMG
- LCM
- LCR
- LCG
- LCX
- STM
- STG
- STR2
- MRL2
- GRC
- Cylinder switch
- MN3E
MN4E
- 4GA/B
- M4GA/B
- MN4GA/B
- FR (module unit)
- Clean F.R
- Precision R
- Press gauge
Diff. press gauge
- Electro-pneumatic R
- Speed controller
- Auxiliary valve
- Fitting/tube
- Clean air unit
- Pressure sensor
- Flow rate sensor
- Valve for air blow
- Ending

Structure/treatment and material restriction

	Structure/treatment	Model No.
P7 Series	Dust generation preventing	- P70

Dimensions and applications

Piping adaptor set

- Model No.: A400*-P70
A800*-P70

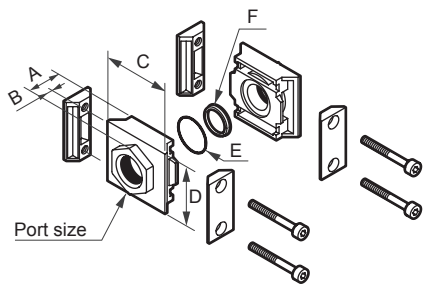

Material: aluminum alloy die-cast coating processing

Model No.	Port size	Applicable model	A	B	C	D	E (O ring)	F (gasket)	Others
A400-8-P70	Rc ¹ / ₄	2000 Series 4000 Series 3000 Series	20 (25) [34]	6 (11) [20]	50	45	JISB2401 P21 1	1	Values in () are for Rc ³ / ₄ . Values in [] are for Rc1.
A400-10-P70	Rc ³ / ₈								
A400-15-P70	Rc ¹ / ₂								
A400-20-P70	Rc ³ / ₄								
A400-25-P70	Rc1								
A800-20-P70	Rc ³ / ₄	6000 Series	35 (38)	15 (18)	81	66	AS568-127 1	1	Values in () are for Rc1 ¹ / ₄ .
A800-25-P70	Rc1								
A800-32-P70	Rc1 ¹ / ₄								

Piping adaptor set

- Model No.: A400*-B31-P70
A400*-B41-P70
A800*-B81-P70
(with T bracket set)

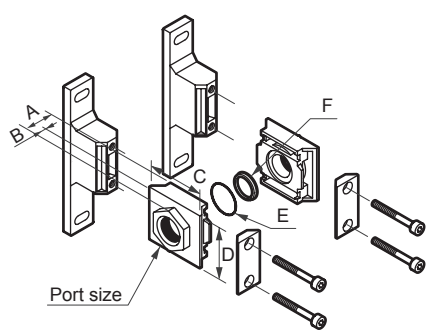

Material: aluminum alloy die-cast coating processing

Model No.	Port size	Applicable model	A	B	C	D	E (O ring)	F (gasket)	Others
A400-8-B31-P70	Rc ¹ / ₄	2000 Series 3000 Series	20	6	50	45	JISB2401 P21 1	1	
A400-10-B31-P70	Rc ³ / ₈								
A400-15-B31-P70	Rc ¹ / ₂								
A400-8-B41-P70	Rc ¹ / ₄	4000 Series	20 (25) [34]	6 (11) [20]	50	45	JISB2401 P21 1	1	Values in () are for Rc ³ / ₄ . Values in [] are for Rc1.
A400-10-B41-P70	Rc ³ / ₈								
A400-15-B41-P70	Rc ¹ / ₂								
A400-20-B41-P70	Rc ³ / ₄								
A400-25-B41-P70	Rc1								
A800-20-B81-P70	Rc ³ / ₄	6000 Series	35 (38)	15 (18)	81	66	AS568-127 1	1	Values in () are for Rc1 ¹ / ₄ .
A800-25-B81-P70	Rc1								
A800-32-B81-P70	Rc1 ¹ / ₄								

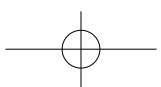

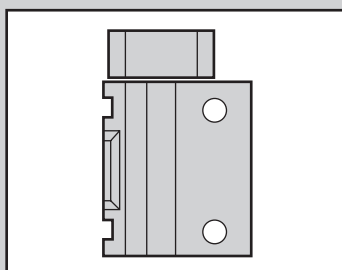

L piping adaptor

A401/A801 Series

Port size: Rc1/4 to Rc1



SCPD3
SCM
SSD2
MDC2
SMG
LCM
LCR
LCG
LCX
STM
STG
STR2
MRL2
GRC
Cylinder Switch
MN3E MN4E
4GA/B
M4GA/B
MN4GA/B
F.R.(module unit)
Clean F.R
Precision R
Press gauge Diff. press gauge
Electro-pneumatic R
Speed controller
Auxiliary valve
Fitting/ tube
Clean air unit
Pressure sensor
Flow rate sensor
Valve for air blow
Ending

Structure/treatment and material restriction

	Structure/treatment	Model No.
P7 Series	Dust generation preventing	- P70

Specifications

Descriptions	A401 ^{*1}	A801
Working fluid	Compressed air	
Max. working pressure	MPa	1.0
Proof pressure	MPa	1.5
Port size	Rc 1/4, 3/8, 1/2	3/4, 1
Ambient temperature/liquid temperature	°C 5 to 50	
Weight	kg 0.13	0.4

*1: A401 can be connected to 2000 Series, 3000 Series, and 4000 Series.

How to order

A401 - 6 - B41 - P70

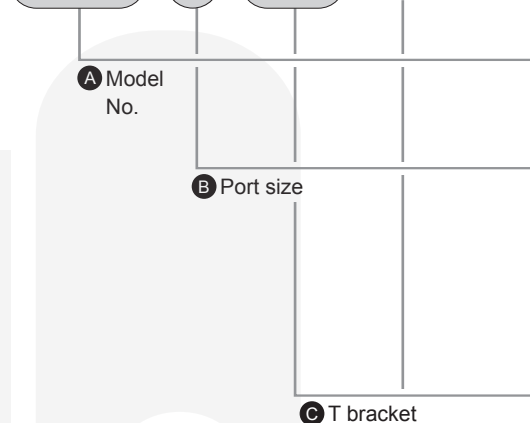

Code	Content		
A Model No.			
A401	L piping adaptor		
A801	L piping adaptor		
B Port size			
		A401	A801
8	Rc1/4	●	
10	Rc3/8	●	
15	Rc1/2	●	
20	Rc3/4		●
25	Rc1		●
C T bracket ^{*1}			
B31	2000, 3000 Series	●	
B41	4000 Series	●	
B81	6000 Series		●
D Clean room specifications			
		Structure	
	P70	Dust generation preventing	

⚠ Precautions for model No. selection

- *1: The joiner set (joiner/bolt/O-ring) and one gasket are enclosed as a standard.
- *2: Consult CKD for top and bottom both sides piping.

L piping adaptor

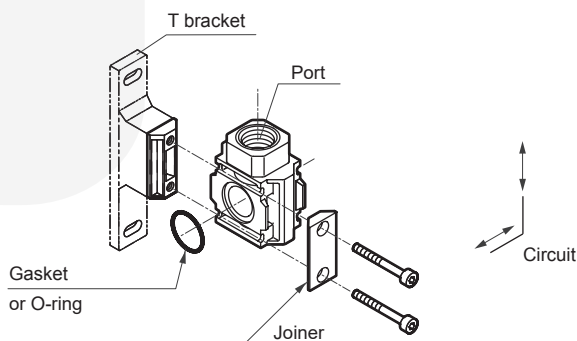

Note: Insert the O-ring when mounting on the primary side, and insert the gasket when mounting on the secondary side for the air flow.

● Examples

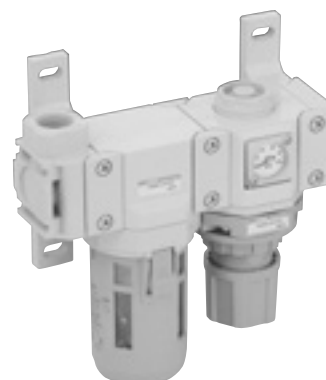

A401/A801 Series

Dimensions

● A401-*-P70

● A801-*-P70

· Material: aluminum alloy die-cast coating processing

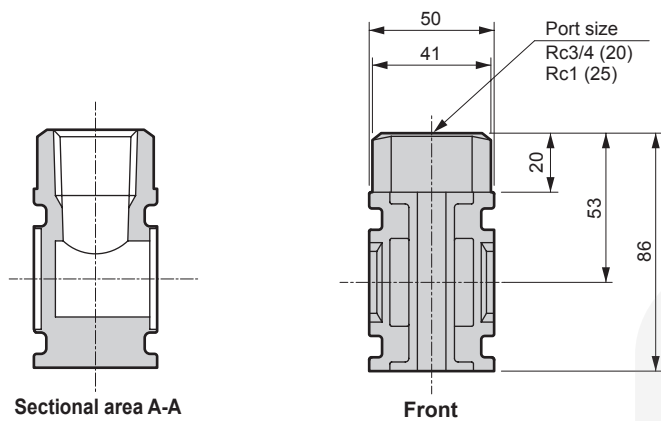
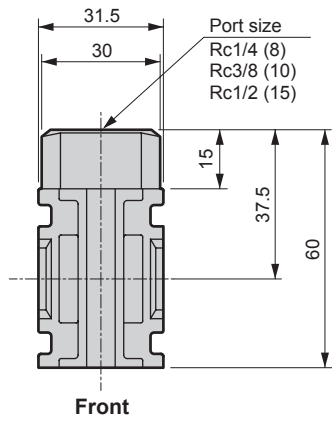
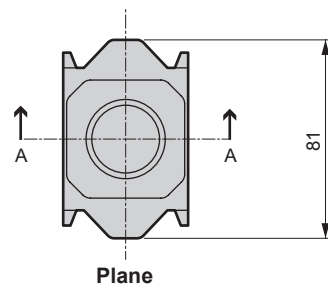
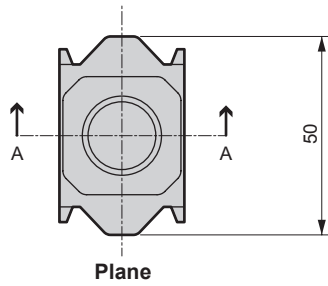

SCPD3
SCM
SSD2
MDC2
SMG
LCM
LCR
LCG
LCX
STM
STG
STR2
MRL2
GRC
Cylinder switch
MN3E
MN4E
4GA/B
M4GA/B
MN4GA/B
F.R (module unit)
Clean F.R
Precision R
Press gauge
Diff. press gauge
Electro-pneumatic R
Speed controller
Auxiliary valve
Fitting/ tube
Clean air unit
Pressure sensor
Flow rate sensor
Valve for air blow
Ending